

2022/09/28

Tender no. H22/005AI



public works
& infrastructure

Department:
Public Works and Infrastructure
REPUBLIC OF SOUTH AFRICA

Private Bag X65, PRETORIA, 0001 / 256 Madiba Street, PRETORIA, 0001 /
Tel. no. 0800 782 542

TENDER DOCUMENT

INVITATION TO TENDER FOR PROFESSIONAL SERVICES:

ARCHITECTURAL SERVICES

FOR THE PROJECT

DEVELOPMENT OF STANDARD DESIGN GUIDELINES FOR THE SOUTH AFRICAN
POLICE SERVICES

WCS: N/A

REFERENCE NO: SAPS DESIGN GUIDELINE

TENDER NO: H22/005AI

SEPTEMBER 2022

Name of tenderer:

ISSUED BY:
THE DIRECTOR-GENERAL
DEPARTMENT OF PUBLIC WORKS & INFRASTRUCTURE

Effective date: 01 August 2022

Version 8.7 ARCH tender

CONTENTS

Page

The Tender

T1: TENDERING PROCEDURES	
T1.1 Notice and Invitation to Tender	3
T1.2 Tender Data	3
T2: RETURNABLE DOCUMENTS	
T2.1 List of Returnable Documents	12
T2.2 Returnable Schedules	12

The Contract

C1: AGREEMENT AND CONTRACT DATA	
C1.1 Form of Offer and Acceptance	37
C1.2 Contract Data	41
C2: PRICING DATA	
C2.1 Pricing Assumptions	51
C2.2 Activity Schedule	56
C3: SCOPE OF SERVICES	
C3 Scope of Services	60
C4: SITE INFORMATION	
C4 Site Information	64

Annexures

- A:** Terms of Reference
- B:** Pricing Schedule

T1: TENDERING PROCEDURES

T1.1 Notice and Invitation to Tender

T1.1.1 The words "**tender**" and "**bid**" in this document or any documents referred to in this document are interchangeable and are deemed to have the same meaning, similarly the words "tenderer" and "tendering Service Provider" are interchangeable and are deemed to have the same meaning. Unless inconsistent with the context, the masculine gender includes the feminine and neuter genders and *vice versa*, and the singular includes the plural and *vice versa*. In this document, words and expressions signified in the text by the use of capital initial letters, shall have the meanings defined in the Standard Professional Services Contract except where the context otherwise requires.

T1.1.2 The Government of the Republic of South Africa in its Department of Public Works invites tenders for the provision of **PROFESSIONAL ARCHITECTURAL SERVICES** as further fully described in C3 Scope of Services hereof.

T1.1.3 The address for collection of tender documents and the telephone number of the tender section are as advertised in the Tender Bulletin.

T1.1.4 Tender documents may be collected on working days **between 07:30 and 12:45** and **between 13:30 and 15:30**.

T1.1.5 A non-refundable deposit of **R 100.00** is payable, in cash only, on collection of the tender documents.

T1.1.6 Queries relating to these documents may be addressed to the Employer's authorised and designated representative who is the departmental project manager:

Ms E Wiese/ H Nienaber

Tel no: 012 406 1372/ 012 406 1369

Cell no: 082 727 6948/ 082 957 3752

Fax: n/a

Physical address: 256 Madiba Street
PRETORIA
0001

Postal address: Private Bag X65
PRETORIA
0001

T1.1.7 The closing time for receipt of tenders is as advertised in the Tender Bulletin. Telephonic, facsimile, electronic and late tenders will not be accepted.

T1.1.8 Requirements for sealing, addressing, delivery, opening and assessment of tenders are stated in T1.2 Tender Data.

T1.2 Tender Data

T1.2.1 Standard Conditions of Tender

The conditions of tender are the **Standard Conditions of Tender** as contained in **Annexure C** of the **Construction Industry Development Board Standard for Uniformity in Engineering and Construction Works Contracts** as per Government Notice No. 423 published in Government Gazette No. 42622 of **8 August 2019** and as amended from time to time.

The Standard Conditions of Tender is not included in this tender document. Tenderers must obtain it on the CIDB's Website at:

http://www.cidb.org.za/procurement/procurement_toolbox/cidb_pub/default.aspx

The Standard Conditions of Tender make several references to the Tender Data for details that apply specifically to this tender. The Tender Data shall have precedence in the interpretation of any ambiguity or inconsistency between it and the Standard Conditions of Tender.

Each item of data given below is cross-referenced to the clauses marked [C] in the Standard Conditions of Tender to which it mainly applies.

By submitting a tender in response to T1.1 Notice and Invitation to Tender above, the tenderer binds himself to a *pactum de contrahendo* (contract aimed at conclusion of another contract), the terms of which are contained in the Standard Conditions of Tender and T1.2 Tender Data.

Clause number	
[C.1.1]	The Employer is the Government of the Republic of South Africa in its Department of Public Works & Infrastructure.
[C.1.2]	<p>For this Contract the single volume approach is adopted.</p> <p>This procurement document has been formatted and compiled under the headings for a single volume approach as contained in table 5 of the CIDB's "Standard for Uniformity in Construction Procurement."</p> <p>The tendering Service Provider's attention is specifically drawn to the T2 Returnable Documents identified in the T2.1 List of Returnable Documents and in the T2.2 Returnable Schedules. The Returnable Documents must be obtained and the Returnable Schedules must be completed by a tenderer when submitting a tender. The tenderer must complete these documents, including the "Offer" document in C1.1 Form of Offer and Acceptance, and deliver his tender back to the Employer bound as it was received.</p> <p>The tender document, issued by the Employer, comprises the following separate identifiable documents collectively forming the "Tender Document in a single volume":</p> <p><u>The Tender</u> T1: Tendering Procedures T1.1 Notice and Invitation to Tender T1.2 Tender Data</p> <p>T2: Returnable Documents T2.1 List of Returnable Documents T2.2 Returnable Schedules</p> <p><u>The Contract</u> C1: Agreement and Contract Data C1.1 Form of Offer and Acceptance C1.2 Contract Data</p> <p>C2: Pricing Data C2.1 Pricing Assumptions C2.2 Activity Schedule</p> <p>C3: Scope of Services</p> <p>C4: Site Information</p>
[C.1.4]	The Employer's agent for the purpose of this tender is deemed to be the authorised and designated representative of the Employer, who will be the departmental project manager as noted in T1.1.6 Notice and Invitation to Tender.

[C.2.1]	<p>Tenders will only be considered for acceptance if (i.e. will only be regarded as responsive if):</p> <ol style="list-style-type: none">1. The tendering Service Provider is an architectural business undertaking, which is under the fulltime supervision of a registered professional architect /s in terms of the Architectural Professions Act, 2000 (Act no 44 of 2000), owning the majority shares or voting power, as determined by the South African Council for the Architectural Profession in its Code of Professional Conduct, and who will hereafter be referred to as registered principals of the business undertaking <p style="text-align: center;">or</p> <p>a multidisciplinary professional practice, that also practises architectural work, which architectural division/section is under the fulltime supervision of a registered professional architect, as determined by any of the relevant professional Councils, where applicable, for cases pertaining to multi-disciplinary practices/business undertakings, in their respective Codes of Professional Conduct, in terms of number, shareholding and voting power, who are registered in terms of the Architectural Professions Act, 2000 (Act no 44 of 2000), Landscape Architectural Profession Act, 2000 (Act no 45 of 2000), Engineering Profession Act, 2000 (Act no 46 of 2000), Construction and Project Management Profession Act, 2000 (Act no 48 of 2000) and/or Quantity Surveying Profession Act, 2000 (Act no 49 of 2000), and who will hereafter be referred to as registered principals.</p> <p>In the event of any legal entity, as meant above, being a listed public Company on the stock exchange, the percentages related to ownership and control referred to are to be made relevant to persons duly appointed as Directors of such entity.</p> <ol style="list-style-type: none">2. Copies of certificates or other documentation clearly proving current professional registration with the relevant council, including registration numbers, of all the registered principals mentioned in 1 above are included with the tender as part of the returnable documentation. In the event of any legal entity, as meant above, being a private Company with shareholding, the same information/documentation as for registered principals must be provided with the tender, in respect of all Directors formally appointed to manage the business undertaking. Sole Proprietors, Partners in Partnerships, and Members of Close Corporations are principals as defined in 1 above and information/documentation in respect of such persons must be provided as described;3. The information, required in respect of 1 and 2 above, has been provided for all Service Providers tendering in consortium or joint venture;4. At least one registered professional architect, of whom the same documentation as in 2 above has been included in the tender of the tendering Service Provider, has been listed in C1.2.3, clause 7.1.2 Key Persons; <p>[The Employer retains the right to verify current professional registration required in terms of 2, 3 and 4 above with the relevant council as part of the tender evaluation process. In the event of any such person not currently being registered with the relevant council, it will render the tender as unacceptable (i.e. non-responsive) and excluded from further consideration.]</p> <ol style="list-style-type: none">5. All Returnable Documents mentioned in T2: Returnable Documents (T2.1 List of Returnable Documents and T2.2 Returnable Schedules) have been included in the tender;6. (a) The tendering Service Provider has provided the required information/documentation to enable an evaluation panel to perform functionality and risk assessments as described in 6(b) and 6(c) hereafter and referred to in T2.1 – sub paragraph 4;
---------	--

(b) Tender offers are judged by an evaluation panel in terms of functionality, which functionality will be evaluated against the following criteria on a scoring system of 1 to 5, weighted as indicated:

Note: Bids will be evaluated solely on the basis of price and preference. Functionality will be applied as a criterion for assessing risk to the Employer on projects with a threshold over R500 000.

Note: Functionality will be applied as a prequalification criterion. Such criteria is used to establish minimum requirements where after bids will be evaluated solely on the basis of price and preference.

Functionality Criteria	Weighting Factor
<p>Qualifications and experience of the Project leader The service provider for this project should indicate the allocated Project Leader's experience in work of a similar nature and scope. The Project Leader shall be in the full time employ of the service provider. (Bidders to attach and indicate experience and references in their CV) The project leader must have a Post grad/Bachelor qualification in Architecture and a minimum of 15 years' experience in the respective field as well as professional registration with the relevant council.</p> <p>20 years' experience and above = 5 points 18-19+ years' experience = 4 points 15-17+ years' experience = 3 points Less than 15 years' experience = 0 points</p>	20
<p>Qualifications and experience of the Key specialists (Project team) The project team must have at least one (1) member that has a Bachelor qualification in Architecture and a minimum of 10 years' experience in the said field as well as professional registration with the relevant council.</p> <p>15 years' experience and above = 5 points 13-14+ years' experience = 4 points 10-12+ years' experience = 3 points Less than 10 years' experience = 0 points</p>	20
<p>Relevant experience in projects of similar scale and nature Proven experience of completed projects of similar scale and nature of the project as specified as follow: 1) Development and assembly of existing policies, guidelines 2) Generic building design guidelines</p> <p>Note: Where the entity tendering is a joint venture a score for track record will be awarded to each party to the joint venture, which will then be combined in proportion to the percentage contribution of each party to the joint venture.</p> <p>Projects of similar nature (as per DPW-09), delivered within the given timeframe: 6 Projects and above = 5 points 5 Projects = 3 points Less than 5 Projects = 1 point</p>	20
<p>Value Added Demonstration that the client will derive better value for money by contracting with the tenderer in providing the following:</p> <ol style="list-style-type: none"> 1. New and innovative knowledge in terms of International benchmarking; 2. Methodology to transfer knowledge to NDPWI team; 	10

<p>3. Use of BIM technology; 4. Demonstration of project appropriateness to public infrastructure; 5. Quality of proposal presentation.</p> <p>Providing information on all five (5) items above = 5 points Providing information on four (4) items above = 4 points Providing information on three (3) items above = 3 points Failure to provide information on less than three (3) items above = 0 points</p>			
<p>Proposed programme plan Demonstrate the approach/ methodology to follow with this project by providing information on each of the following subheadings:</p> <ol style="list-style-type: none"> 1. Approach/ methodology for this project 2. Approach to quality control, 3. Approach to project management, and 4. Approach to team communication. 5. Quality of project comprehension demonstrated in proposal i.e. project execution plan, proposed timeframe for the project <p>Providing information on all five (5) items above = 5 points Providing information on four (4) items above = 3 points Failure to provide information on less than four (4) items above = 0 points</p>	<p>30</p>		
<p>Total</p>	<p>100 Points</p>		
<p>(Weightings will be multiplied by the scores allocated during the evaluation process to arrive at the total functionality points)</p>			
<table border="1" style="width: 100%;"> <tr> <td style="width: 80%;">Minimum functionality score to qualify for further evaluation:</td> <td style="text-align: center;">60</td> </tr> </table>		Minimum functionality score to qualify for further evaluation:	60
Minimum functionality score to qualify for further evaluation:	60		
<p>(c) Tender offers are judged by an evaluation panel in terms of risk to the Employer. Such risk will be evaluated against technical and commercial risk criteria listed below. Such risk will be evaluated against the criteria listed below. Each criterion carries the same weight / importance and will be evaluated individually by the Bid Evaluation Committee appointed on the project. An assessment of unacceptable risk on any single criterion will constitute unacceptable risk for the award as a whole, resulting in the tender to be disqualified and removed from further consideration.</p> <p>In order for the evaluation reports to be prepared by the Bid Evaluation Committee, the Tenderer is obliged to provide comprehensive information on form DPW-09 (EC). Failure to complete the said form will cause the tender to be declared non-responsive and removed from any further consideration. Information provided in the returnable documentation must be provided in sufficient detail to enable the evaluation panel to evaluate the risk criteria set out below.</p> <p>The Employer reserves the right to request further clarification, elucidation, additional documentation / information, etc. as may be required to evaluate the tender. The aforementioned can also entail that the persons, named in the schedule of Key Persons (C1.2.3 Data provided by the Service Provider, clause 7.1.2), be invited to an interview.</p> <p>The information must be provided by the Tenderer within the stipulated time as determined by the Bid Evaluation Committee, failing which the tender offer will <i>mutatis mutandis</i> be declared non-responsive.</p>			

The risk criteria are as follows:

Technical risks:

Criterion 1: Experience on comparable projects during the past 5 years.

The tendering Service Provider's experience on comparable projects during the past 5 years. The number of current and previous comparable projects performed by the Tenderer as per the evaluation report prepared by the Bid Evaluation Committee, based on its research and inspection of a representative sample of the Tenderer's current and previous work as reflected on form DPW-09 (EC), as well as, if necessary, of any additional work executed by the Tenderer, not reflected on form DPW-09 (EC).

Aspects to be regarded as "comparable" includes (but may be extended according to circumstances): size of projects (measured against monetary value or other project quantifying parameters), nature of projects (building, engineering, high/low rise, etc.), locality/area of execution (site-specific influences, knowledge of local conditions, etc.), complexity of project, projects for similar client department irrespective of end purpose of buildings/facilities created or in progress of being created and time scales of projects (normal, fast track, etc.) and stage of its/their development.

[An opinion will be formed by each of the members of an evaluation panel according to his/her assessment of the experience and performance of the tendering Service Provider from information submitted with the tender (in written-, report- and/or brochure format), and upon further investigations/reference checks that may be performed, for which purpose the tendering Service Provider must include names and contact particulars of present and previous Employers to whom services are/were rendered. The Employer retains the right to contact references not mentioned by the tendering Service Provider. Members of the evaluation panel will discuss their respective risk perceptions in order to reach consensus, failing which the specific risk will be put to the vote. **No risk assessment will be performed for this criterion in the absence of relevant information with the tender and will therefore render the tender as unacceptable and excluded from further consideration.]**

Criterion 2: Contractual commitment and quality of performance on comparable projects during the past 5 years.

Adherence to contractual commitments and quality of performance of comparable current and previous projects performed by the Tenderer as per the evaluation report prepared by the Bid Evaluation Committee, based on its research and inspection of a representative sample of the Tenderer's current and previous work as reflected on form DPW-09 (EC), as well as, if necessary, of any additional work executed by the Tenderer, not reflected on form DPW-09 (EC).

Aspects to be considered include but not limited to time management & programming, quality of detailed designs, extent of variations to scope due to shortcomings in original designs, compliance to relevant regulations, personnel resources & technical experience of representatives, turnover in representatives, decision making & problem solving skills, promptness and quality of contract administration in terms of reporting and issuing contract documents, attending site meetings, scope management, leadership and accountability, conformance to specification and quality compliance, risk Identification and mitigation, all with respect to specific aspects of the project / comparable projects and the project tendered for.

[An opinion will be formed by each of the members of an evaluation panel according to his/her assessment of the experience and performance of the tendering Service Provider from information submitted with the tender (in written-, report- and/or brochure format), and upon further investigations/reference checks that may be performed, for which purpose the tendering Service Provider must include names and contact particulars of present and previous Employers to whom services are/were rendered. The Employer retains the right to contact references not mentioned by the tendering Service Provider.

Members of the evaluation panel will discuss their respective risk perceptions in order to reach consensus, failing which the specific risk will be put to the vote. **No risk assessment will be performed for this criterion in the absence of relevant information with the tender and will therefore render the tender as unacceptable and excluded from further consideration.]**

Criterion 3: Suitably qualified and appropriately experienced human resources

Allocation of suitably qualified and appropriately experienced human resources, both in respect of principals and/or other staff (professional, technical and/or administrative) of the tendering Service Provider to the project, as described in the schedule of Key Persons in terms of clause 7.1.2 of the General Conditions of Contract, as proof that the tendering Service Provider will be able to react/respond appropriately to the Services required herein. The Company Organogram with CV's and certified ID's of all principals and employed workforce as well as proof of Professional Registration will be verified. Current and future workload of the tenderer in relation to capacity and capability will also be considered. The tenderer should demonstrate that he or she possesses the necessary professional and technical qualifications, and professional and technical competence in relation to the scope of work and service to be rendered.

[An opinion will be formed by each of the members of an evaluation panel according to his/her assessment of the qualifications and experience of the human resources allocated to the project in terms of the Key Persons (C1.2.3 Data provided by the Service Provider, clause 7.1.2), from information contained in curriculum/curricula vitae submitted with the tender. Members of the evaluation panel will discuss their respective risk perceptions in order to reach consensus, failing which the specific risk will be put to the vote. **No risk assessment will be performed for this criterion in the absence of relevant information / curricula vitae with the tender and will therefore render the tender as unacceptable and excluded from further consideration.]**

Criterion 4: Proof of Professional Indemnity Insurance

Confirmation of the required level of professional indemnity insurance specified in terms of Contract Data clause 5.4.1 (C1.2.3 Data provided by the Service Provider).

[If confirmation/proof of professional indemnity insurance is not duly confirmed in C1.2.3 Data provided by the Service Provider, the risk to Employer will be regarded as unacceptable and render the tender unacceptable on grounds of not being to specification. The Employer retains the right to request documentary proof of such insurance as part of the tender evaluation process. **Unconfirmed professional indemnity insurance will render the tender as unacceptable in terms of risk to the Employer and excluded from further consideration.]**

Criterion 5: Attendance of compulsory bid clarification meeting, if applicable

If applicable, submission of confirmation of DPW-16.1 (PSB) attendance of compulsory bid clarification meeting or proof of attending the compulsory virtual meeting by a suitably qualified and experienced representative of the tendering Service Provider in terms of clause [C.2.7] (T1.2 - Tender Data).

[Non-attendance, if compulsory in terms of [C.2.7], will be regarded as a risk to the Employer in that salient information required for tender purposes would not have been to the knowledge of the tendering Service Provider, rendering any resultant tender to be incomplete. **Non-attendance will render the tender a risk to the Employer and therefore excluded from further consideration.**

[In the event of the clarification meeting not being compulsory, this risk criterion will not be applicable.]

Commercial risks:

The financial viability assessment evaluates the risk over the life of the service contract period, as to whether the tenderer will be able to deliver the goods and services which are

	<p>specified in the contract and / or be able to fulfil guarantees or warranties provided for in the contract in order to complete the project successfully for the amount tendered.</p> <p>Aspects to be considered include but not limited to, the respective rates tendered, bank rating, financial capability and capacity whether the tenderer has or has access to sufficient financial resources to deliver the goods or services described in the tender documentation (including fulfilling any guarantees or warranty claims), whether the tenderer is not subject to any current or impending legal action (either formal proceedings or notification of legal action) which could impact on the financial standing of the tenderer or the delivery of the goods or services, management accounts / financial report from auditors as proof of current liquidity, and company or any parent company or investor guarantee/s and financial statements.</p> <p>[An opinion will be formed by each of the members of an evaluation panel according to his/her assessment of the financial viability of the amount tendered in order to render the service. Members of the evaluation panel will discuss their respective risk perceptions in order to reach consensus, failing which the specific risk will be put to the vote. No risk assessment will be performed for this criterion in the absence of relevant information/ curricula vitae with the tender and will therefore render the tender as unacceptable and excluded from further consideration.]</p> <p>Other <u>project specific</u> risk criteria: Not applicable</p> <p>Note: Any tender not complying with <u>all</u> of the above-mentioned stipulations will be regarded as non-responsive and will therefore <u>not</u> be considered for further evaluation.</p>
[C.2.7]	<p>A tender clarification meeting will be held in respect of this tender virtually. Attendance of said clarification meeting is compulsory.</p> <p>The particulars for said tender clarification meeting are: Location: N/A Venue: N/A Virtual Meeting: A compulsory briefing session will be held via zoom. Bidders who are interested to attend the Briefing Session must send their email addresses to helene.nienaber@dpw.gov.za & joseph.nyalunga@dpw.gov.za in advance in order to receive the meeting link a day prior the meeting. Only two email addresses will be allowed per bidder and not more than that. Date: 07 October 2022 Starting time: 10:00</p>
[C.2.13.3]	Each tender offer communicated on paper shall be submitted as an original. Each page of the tender document shall be initialled by the Authorised Signatory as per the Resolution of the Board of Directors, Consortia or Joint Venture in terms of PA15.1, PA15.2 or PA15.3.
[C.2.13.4]	Delete the last sentence of the paragraph: "Signatories for ... of the tender offer."
[C.2.13.5]	<p>The Employer's addresses for delivery of tender offers are as advertised in the Tender Bulletin.</p> <p>In addition, the following identification details must be provided on the <u>back</u> of the envelope: Tenderer's name, contact address and telephone number and in the top left corner on the back of the envelope: "Tender no. " (and fill in the tender number as on the front page hereof) "WCS no. " (and fill in the WCS number as on the front page hereof) "Tender for Architectural Services".</p>
[C.2.13.6]	A two-envelope procedure will not be followed.
[C.2.15]	The closing time for submission of tenders is as advertised in the Tender Bulletin.
[C.2.16]	The tender validity period is 84 days from date of tender closure.

[C.2.19]	The tenderer shall provide access for inspections to his offices as may be required by the Employer.
[C.2.22]	Not a requirement.
[C.2.23]	The tenderer is required to submit with his tender all documents listed in T2 Returnable Documents, T2.1 and T2.2.
[C.3.4]	The time and location for opening tender offers are: Time: tenders will be opened immediately or as soon as possible after the closing time as advertised in the Tender Bulletin; Location: CGO Building, 256 Madiba Street, PRETORIA
[C.3.5]	A two-envelope procedure will not be followed.
[C.3.9.3]	Omit the wording and replace with the following: "Notify the tenderer of all errors, omissions and/or rate imbalances that are identified in the tender offer and request the tenderer to, within a stipulated time, accept the total of prices as corrected in accordance with C.3.9.4."
[C.3.9.4]	Omit the wording of the first sentence and replace with: "In cases where tender offers contain errors, omissions and/or rate imbalances, these are to be corrected as follows:" Add sub-paragraph c) as follows: "c) If the tenderer does not accept the corrected tender offer, or cannot reach consensus with the Employer on a corrected tender offer, the tenderer is to be classified as not acceptable/non-responsive and removed from further contention."
[C.3.11]	The procedure for the evaluation of responsive tenders is Method 2: Financial Offer and Preference.
[C.3.17]	The number of paper copies of the signed contract to be provided by the employer is <u>one</u> .

T2: RETURNABLE DOCUMENTS

This tender document in its entirety, all returnable documents which must be attached to this tender document, and all returnable schedules must be returned when the tender is submitted.

T2.1 List of Returnable Documents (to be obtained/compiled by the tenderer and attached to this tender). All documents must be duly completed and signed where applicable.

1. Copies of present registration, with the registration numbers, of all the registered principals and professionals mentioned under T1.2 Tender Data, clause [C.2.1], item 2, as well as in C1.2.3 Data provided by the Service Provider, clause 7.1.2 Key Persons, with the **South African Council for the Architectural Profession** as "Professional Architects".
2. A valid original or certified copy of B-BBEE status level verification certificate.
3. An exposition, with necessary annexures, in suitable format and in sufficient detail, providing all the information necessary for the evaluation panel to be able to evaluate the functionality and risk set out in T1.2 Tender Data, clause [C.2.1].

T2.2 Returnable Schedules (all bound into this tender document – to be completed by tenderer) All documents must be duly completed and signed where applicable.

T2.2.1 SUBSTANTIVE COMPLIANCE RESPONSIVENESS CRITERIA

Failure to submit fully completed documents as stated hereunder shall result in the tender offer being disqualified from further consideration:

1	<input checked="" type="checkbox"/>	Only those tenderers who satisfy the eligibility criteria stated in the Tender Data may submit tenders.
2	<input checked="" type="checkbox"/>	Tender offer must be properly received on the tender closing date and time specified on the invitation, completed either electronically (if issued in electronic format), or by writing legibly in non-erasable ink. (All as per Standard Conditions of Tender).
3	<input checked="" type="checkbox"/>	Use of correction fluid is prohibited. Corrections to be crossed out and initialled.
4	<input checked="" type="checkbox"/>	Submission of Form of Offer and Acceptance (C1.1),
5	<input checked="" type="checkbox"/>	Submission of fully completed (C2.2) Activity Schedule for Time Based Fees, which is applicable in accordance with C2.1.1.1.
6	<input type="checkbox"/>	Submission of DPW-09 (PSB): Particulars of Tenderer's Projects.
7	<input type="checkbox"/>	Submission of (PA-16): Preference points claim form in terms of the Preferential Procurement Regulations 2017.
8	<input type="checkbox"/>	Submission of DPW-21 (EC): Record of Addenda to tender documents.
9	<input checked="" type="checkbox"/>	Provide proof of valid professional registration and other documentation relating to eligibility to tender as contained in (C.2.1 of T1.2 -Tender Data).
10	<input checked="" type="checkbox"/>	Data provided by the Service Provider (C1.2.3) fully completed.
11	<input type="checkbox"/>	Submission of DPW-16.1 (PSB): Tender Clarification Meeting Certificate as proof of attendance of compulsory tender clarification meeting. <i>insert motivation why the tender clarification meeting is declared compulsory</i>
12	<input checked="" type="checkbox"/>	Submission of Proof of attending compulsory virtual tender clarification meeting. <i>A compulsory meeting is required to convey salient information required for tender purposes that would not otherwise be knowledgeable to the Tenderer. Also, this is not a standard Architectural Service required.</i>
13	<input type="checkbox"/>	<i>Specify other responsiveness criteria</i>
14	<input type="checkbox"/>	<i>Specify other responsiveness criteria</i>

T2.2.2 ADMINISTRATIVE RESPONSIVENESS CRITERIA

The Employer reserves the right to request further information regarding the undermentioned criteria. Failing to submit further clarification and/or documentation within 7 calendar days from request will disqualify the tender offer from further consideration.

1	<input checked="" type="checkbox"/>	Any correction to be initialled by the person authorised to sign the tender documentation as per PA 15.1 or PA 15.2 resolution of board/s of directors / or PA15.3 Special Resolution of Consortia or JV's.
2	<input checked="" type="checkbox"/>	Submission of applicable (PA-15.1, PA-15.2, PA-15.3): Resolution by the legal entity, or consortium / joint venture, authorising a dedicated person(s) to sign documents on behalf of the firm / consortium / joint venture.
3	<input checked="" type="checkbox"/>	Submission of (PA-11): Bidder's disclosure
4	<input checked="" type="checkbox"/>	Submission of PA-16.1 (PSB): Ownership Particulars
5	<input checked="" type="checkbox"/>	Submission of documentation relating to risk assessment criteria as contained in C 2.1 of T1.2 Tender Data.
6	<input checked="" type="checkbox"/>	Submission of proof of Registration on National Treasury's Central Supplier Database (CSD). Insert the Supplier Registration Number on the form of offer.
7	<input checked="" type="checkbox"/>	All parts of tender documents submitted must be fully completed in ink and signed where required.
8	<input type="checkbox"/>	Upon request, submission of fingerprints obtainable from local SAPS including any other additional documentation and information required for vetting purposes.
9	<input type="checkbox"/>	Upon request, submission of a fully completed security clearance application form with supporting documentation and information as required. The security clearance form will be provided by the Employer for projects requiring a security clearance.
10	<input checked="" type="checkbox"/>	Submission of (PA-16): Preference points claimed form in terms of the Preferential Procurement Regulations 2017
11	<input checked="" type="checkbox"/>	Submission of DPW-09 (PSB): Particulars of Tenderer's Projects
12	<input checked="" type="checkbox"/>	Submission of proof of Registration on National Treasury's Central Supplier Database (CSD) for all sub-consultants/ specialists
13	<input type="checkbox"/>	Specify other responsiveness criteria
14	<input type="checkbox"/>	Specify other responsiveness criteria
15	<input type="checkbox"/>	Specify other responsiveness criteria

PA-16.1 (PSB): OWNERSHIP PARTICULARS

- NB:** 1. This form is to be read with the Notice and Invitation to Tender and [C.2.1] sub paragraphs 1 and 2 of the Tender Data pertaining to this Tender, and completed according to the definitions and information contained in said documents.
2. **Failure to complete this form may result in the tender being disqualified.**

Project title:	Architectural services for: DEVELOPMENT OF STANDARD DESIGN GUIDELINES FOR THE SOUTH AFRICAN POLICE SERVICES
Tender / Quotation no:	H22/005A1

1. REQUIRED DOCUMENTARY PROOF

The following documentation must be included in the tender as part of the Returnable Documents. Failure to provide the said documentation may result in the tender being disqualified.

Legal Status of Tendering Entity: If the Tendering Entity is:	Documentation to be submitted with the tender:
a. A close corporation, incorporated prior to 1 May 2011 under the Close Corporations Act, 1984 (Act 69 of 1984, as amended)	Copies of the Founding Statement – CK1
b. A profit company duly registered as a private company. [including a profit company that meets the criteria for a private company, whose Memorandum of Incorporation states that the company is a personal liability company in terms of Section 8(2)(c) of the Companies Act, 2008 (Act 71 of 2008, as amended)].	Copies of: i. Certificate of Incorporation – CM1; ii. Shareholding Certificates of all Shareholders of the company, plus a signed statement of the company's Auditor, certifying each Shareholder's ownership / shareholding percentage relative to the total; and/or iii. Memorandum of Incorporation in the case of a personal liability company.
c. A profit company duly registered as a private company in which any, or all, shares are held by one or more other close corporation(s) or company(ies) duly registered as profit or non-profit company(ies).	Copies of documents referred to in a. and/or b. above in respect of all such close corporation(s) and/or company(ies).
d. A profit company duly registered as a public company.	Copy of Certificate of Incorporation – CM1, and a signed statement of the company's Secretary or Auditor confirming that the company is a public company.
e. A non-profit company, incorporated in terms of Section 10 and Schedule 1 of the Companies Act, 2008 (Act 71 of 2008, as amended).	Copies of: i the Founding Statement – CK1; and ii the Memorandum of Incorporation setting out the object of the company, indicating the public benefit, cultural or social activity, or communal or group interest.
f. A natural person, sole proprietor or a Partnership	Copy(ies) of the Identity Document(s) of: i. such natural person/ sole proprietor, or ii. each of the Partners to the Partnership.
g. A Trust	Deed of Trust duly indicating names of the Trustee(s) and Beneficiary (ies) as well as the purpose of the Trust and the mandate of the Trustees.

DPW-09 (PSB): PARTICULARS OF TENDERER'S PROJECTS

Project title:	DEVELOPMENT OF STANDARD DESIGN GUIDELINES FOR THE SOUTH AFRICAN POLICE SERVICES		
Tender / Quotation no:	H22/005AI	Closing date:	27/10/2022
Advertising date:	30/09/2022	Validity period:	84 days

Note: The Tenderer is required to furnish the following particulars and to attach additional pages if more space is required.

1. PARTICULARS OF THE TENDERER'S CURRENT AND PREVIOUS COMMITMENTS

1.1. Current projects

Projects currently engaged in	Name of Employer or Representative of Employer	Contact tel. no.	Contract sum of Project	Scope of Services (Work stages appointed for – e.g. 1 to 6)	Work stages completed	Work stages in progress
1						
2						
3						
4						
5						
6						
7						

1.2. Completed projects

Projects completed in the last 5 (five) years	1	2	3	4	5	6	7	8	9
Name of Employer or Representative of Employer									
Contact tel. no.									
Contract sum of Project									
Scope of Services (Work stages appointed for – e.g. 1 to 6)									
Date of appointment									
Date of completion									

			Name of Tenderer
			Signature
			Date

PA- 40: DECLARATION OF DESIGNATED GROUPS FOR PREFERENTIAL PROCUREMENT

Name of Tenderer EME¹ QSE² Non EME/QSE (tick applicable box)

1. LIST ALL PROPRIETORS, MEMBERS OR SHAREHOLDERS BY NAME, IDENTITY NUMBER, CITIZENSHIP AND DESIGNATED GROUPS.

Name and Surname #	Identity/ Passport number and Citizenship##	Percentage owned	Black	Indicate if youth	Indicate if woman	Indicate if person with disability	Indicate if living in rural / under developed area/township	Indicate if military veteran
1.		%	<input type="checkbox"/> Yes <input type="checkbox"/> No	<input type="checkbox"/> Yes <input type="checkbox"/> No	<input type="checkbox"/> Yes <input type="checkbox"/> No	<input type="checkbox"/> Yes <input type="checkbox"/> No	<input type="checkbox"/> Yes <input type="checkbox"/> No	<input type="checkbox"/> Yes <input type="checkbox"/> No
2.		%	<input type="checkbox"/> Yes <input type="checkbox"/> No	<input type="checkbox"/> Yes <input type="checkbox"/> No	<input type="checkbox"/> Yes <input type="checkbox"/> No	<input type="checkbox"/> Yes <input type="checkbox"/> No	<input type="checkbox"/> Yes <input type="checkbox"/> No	<input type="checkbox"/> Yes <input type="checkbox"/> No
3.		%	<input type="checkbox"/> Yes <input type="checkbox"/> No	<input type="checkbox"/> Yes <input type="checkbox"/> No	<input type="checkbox"/> Yes <input type="checkbox"/> No	<input type="checkbox"/> Yes <input type="checkbox"/> No	<input type="checkbox"/> Yes <input type="checkbox"/> No	<input type="checkbox"/> Yes <input type="checkbox"/> No
4.		%	<input type="checkbox"/> Yes <input type="checkbox"/> No	<input type="checkbox"/> Yes <input type="checkbox"/> No	<input type="checkbox"/> Yes <input type="checkbox"/> No	<input type="checkbox"/> Yes <input type="checkbox"/> No	<input type="checkbox"/> Yes <input type="checkbox"/> No	<input type="checkbox"/> Yes <input type="checkbox"/> No
5.		%	<input type="checkbox"/> Yes <input type="checkbox"/> No	<input type="checkbox"/> Yes <input type="checkbox"/> No	<input type="checkbox"/> Yes <input type="checkbox"/> No	<input type="checkbox"/> Yes <input type="checkbox"/> No	<input type="checkbox"/> Yes <input type="checkbox"/> No	<input type="checkbox"/> Yes <input type="checkbox"/> No
6.		%	<input type="checkbox"/> Yes <input type="checkbox"/> No	<input type="checkbox"/> Yes <input type="checkbox"/> No	<input type="checkbox"/> Yes <input type="checkbox"/> No	<input type="checkbox"/> Yes <input type="checkbox"/> No	<input type="checkbox"/> Yes <input type="checkbox"/> No	<input type="checkbox"/> Yes <input type="checkbox"/> No
7.		%	<input type="checkbox"/> Yes <input type="checkbox"/> No	<input type="checkbox"/> Yes <input type="checkbox"/> No	<input type="checkbox"/> Yes <input type="checkbox"/> No	<input type="checkbox"/> Yes <input type="checkbox"/> No	<input type="checkbox"/> Yes <input type="checkbox"/> No	<input type="checkbox"/> Yes <input type="checkbox"/> No
8.		%	<input type="checkbox"/> Yes <input type="checkbox"/> No	<input type="checkbox"/> Yes <input type="checkbox"/> No	<input type="checkbox"/> Yes <input type="checkbox"/> No	<input type="checkbox"/> Yes <input type="checkbox"/> No	<input type="checkbox"/> Yes <input type="checkbox"/> No	<input type="checkbox"/> Yes <input type="checkbox"/> No
9.		%	<input type="checkbox"/> Yes <input type="checkbox"/> No	<input type="checkbox"/> Yes <input type="checkbox"/> No	<input type="checkbox"/> Yes <input type="checkbox"/> No	<input type="checkbox"/> Yes <input type="checkbox"/> No	<input type="checkbox"/> Yes <input type="checkbox"/> No	<input type="checkbox"/> Yes <input type="checkbox"/> No
10.		%	<input type="checkbox"/> Yes <input type="checkbox"/> No	<input type="checkbox"/> Yes <input type="checkbox"/> No	<input type="checkbox"/> Yes <input type="checkbox"/> No	<input type="checkbox"/> Yes <input type="checkbox"/> No	<input type="checkbox"/> Yes <input type="checkbox"/> No	<input type="checkbox"/> Yes <input type="checkbox"/> No

Where Owners are themselves a Company, Close Corporation, Partnership etc., identify the ownership of the Holding Company, together with Registration number
State date of South African citizenship obtained (not applicable to persons born in South Africa)

¹ EME: Exempted Micro Enterprise

² QSE: Qualifying Small Business Enterprise

2. DECLARATION:

The undersigned, who warrants that he/she is duly authorized to do so on behalf of the Tenderer, hereby confirms that:

- 1 The information and particulars contained in this Affidavit are true and correct in all respects;
- 2 The Broad-based Black Economic Empowerment Act, 2003 (Act 53 of 2003), Preferential Procurement Policy Framework Act, 2000 (Act 5 of 2000), the Preferential Procurement Regulations, 2017, National Small Business Act 102 of 1996 as amended and all documents pertaining to this Tender were studied and understood and that the above form was completed according to the definitions and information contained in said documents;
- 3 The Tenderer understands that any intentional misrepresentation or fraudulent information provided herein shall disqualify the Tenderer's offer herein, as well as any other tender offer(s) of the Tenderer simultaneously being evaluated, or will entitle the Employer to cancel any Contract resulting from the Tenderer's offer herein;
- 4 The Tenderer accepts that the Employer may exercise any other remedy it may have in law and in the Contract, including a claim for damages for having to accept a less favourable tender as a result of any such disqualification due to misrepresentation or fraudulent information provided herein;
- 5 Any further documentary proof required by the Employer regarding the information provided herein, will be submitted to the Employer within the time period as may be set by the latter;

Signed by the Tenderer

Name of representative	Signature
	Date

DPW-16.1 (PSB): TENDERCLARIFICATION MEETING CERTIFICATE

Project title:	Architectural services for: DEVELOPMENT OF STANDARD DESIGN GUIDELINES FOR THE SOUTH AFRICAN POLICE SERVICES		
Tender / Quotation no:	H22/005AI	Reference no:	SAPS Design Guideline

This is to certify that I, _____

representing _____

attended the tender clarification meeting on: _____

I further certify that I am satisfied with the description of the work and explanations given at the tender clarification meeting and that I understand the work to be done, as specified and implied, in the execution of this contract.

Name of Tenderer	Signature	Date

Name of DPW Representative	Signature	Date

PA-11: BIDDER'S DISCLOSURE

Project title:	Architectural services for: DEVELOPMENT OF STANDARD GUIDELINES FOR THE SOUTH AFRICAN POLICE SERVICES		
Tender / Quotation no:	H22/005AI	Reference no:	SAPS Design Guideline

1. PURPOSE OF THE FORM

Any person (natural or juristic) may make an offer or offers in terms of this invitation to bid. In line with the principles of transparency, accountability, impartiality, and ethics as enshrined in the Constitution of the Republic of South Africa and further expressed in various pieces of legislation, it is required for the bidder to make this declaration in respect of the details required hereunder.

Where a person/s are listed in the Register for Tender Defaulters and / or the List of Restricted Suppliers, that person will automatically be disqualified from the bid process.

2. BIDDER'S DECLARATION

- 2.1 Is the bidder, or any of its directors / trustees / shareholders / members / partners or any person having a controlling interest³ in the enterprise, employed by the state?

YES NO

- 2.1.1 If so, furnish particulars of the names, individual identity numbers, and, if applicable, state employee numbers of sole proprietor/ directors / trustees / shareholders / members/ partners or any person having a controlling interest in the enterprise, in table below.

Full Name	Identity Number	Name of State institution

⁽³⁾ the power, by one person or a group of persons holding the majority of the equity of an enterprise, alternatively, the person/s having the deciding vote or power to influence or to direct the course and decisions of the enterprise.

2.2 Do you, or any person connected with the bidder, have a relationship with any person who is employed by the procuring institution? YES NO

2.2.1 If so, furnish particulars:

.....
.....

2.3 Does the bidder or any of its directors / trustees / shareholders / members / partners or any person having a controlling interest in the enterprise have any interest in any other related enterprise whether or not they are bidding for this contract? YES NO

2.3.1 If so, furnish particulars:

.....
.....

3. DECLARATION

I, the undersigned, (name)..... in submitting the accompanying bid, do hereby make the following statements that I declare to be true and complete in every respect:

- 3.1 I have read and I understand the contents of this disclosure;
- 3.2 I understand that the accompanying bid will be disqualified if this disclosure is found not to be true and complete in every respect;
- 3.3 The bidder has arrived at the accompanying bid independently from, and without consultation, communication, agreement or arrangement with any competitor. However, communication between partners in a joint venture or consortium⁴ will not be construed as collusive bidding.
- 3.4 In addition, there have been no consultations, communications, agreements or arrangements with any competitor regarding the quality, quantity, specifications, prices, including methods, factors or formulas used to calculate prices, market allocation, the intention or decision to submit or not to submit the bid, bidding with the intention not to win the bid and conditions or delivery particulars of the products or services to which this bid invitation relates.
- 3.5 The terms of the accompanying bid have not been, and will not be, disclosed by the bidder, directly or indirectly, to any competitor, prior to the date and time of the official bid opening or of the awarding of the contract.
- 3.6 There have been no consultations, communications, agreements or arrangements made by the bidder with any official of the procuring institution in relation to this procurement process prior to and during the bidding process except to provide clarification on the bid submitted where so required by the institution; and the bidder was not involved in the drafting of the specifications or terms of reference for this bid.

⁴ Joint venture or Consortium means an association of persons for the purpose of combining their expertise, property, capital, efforts, skill and knowledge in an activity for the execution of a contract.

- 3.7 I am aware that, in addition and without prejudice to any other remedy provided to combat any restrictive practices related to bids and contracts, bids that are suspicious will be reported to the Competition Commission for investigation and possible imposition of administrative penalties in terms of section 59 of the Competition Act No 89 of 1998 and or may be reported to the National Prosecuting Authority (NPA) for criminal investigation and or may be restricted from conducting business with the public sector for a period not exceeding ten (10) years in terms of the Prevention and Combating of Corrupt Activities Act No 12 of 2004 or any other applicable legislation.

**I DECLARE THAT THE INFORMATION FURNISHED IN PARAGRAPHS 1, 2 and 3 ABOVE IS CORRECT.
I ACCEPT THAT THE STATE MAY REJECT THE BID OR ACT AGAINST ME IN TERMS OF PARAGRAPH 6 OF PFMA SCM INSTRUCTION 03 OF 2021/22 ON PREVENTING AND COMBATING ABUSE IN THE SUPPLY CHAIN MANAGEMENT SYSTEM SHOULD THIS DECLARATION PROVE TO BE FALSE.**

Name of Bidder	Signature	Date	Position

This form is aligned to SBD 4.

PA-15.1: RESOLUTION OF BOARD OF DIRECTORS

RESOLUTION of a meeting of the Board of *Directors / Members / Partners of:

(legally correct full name and registration number, if applicable, of the Enterprise)

Held at _____ *(place)*

on _____ *(date)*

RESOLVED that:

- 1 The Enterprise submits a Tender to the Department of Public Works in respect of the following project:

(project description as per Tender Document)

Tender Number: _____ *(Tender Number as per Tender Document)*

- 2 *Mr/Mrs/Ms: _____

in *his/her Capacity as: _____ *(Position in the Enterprise)*

and who will sign as follows:

be, and is hereby, authorised to sign the Tender, and any and all other documents and/or correspondence in connection with and relating to the Tender, as well as to sign any Contract, and any and all documentation, resulting from the award of the Tender to the Enterprise mentioned above.

	Name	Capacity	Signature
1			
2			
3			
4			
5			
6			
7			
8			
9			
10			
11			
12			

13			
14			
15			
16			
17			
18			
19			
20			

Note:

1. * Delete which is not applicable.
2. **NB:** This resolution must, where possible, be signed by all the Directors / Members / Partners of the Tendering Enterprise.
3. In the event that paragraph 2 cannot be complied with, the resolution must be signed by Directors / Members / Partners holding a majority of the shares / ownership of the Tendering Enterprise (attach proof of shareholding / ownership hereto).
4. Directors / Members / Partners of the Tendering Enterprise may alternatively appoint a person to sign this document on behalf of the Tendering Enterprise, which person must be so authorized by way of a duly completed power of attorney, signed by the Directors / Members / Partners holding a majority of the shares / ownership of the Tendering Enterprise (proof of shareholding / ownership and power of attorney are to be attached hereto).
5. Should the number of Directors / Members / Partners exceed the space available above, additional names and signatures must be supplied on a separate page.

ENTERPRISE STAMP

PA-15.2: RESOLUTION OF BOARD OF DIRECTORS TO ENTER INTO CONSORTIA OR JOINT VENTURES

RESOLUTION of a meeting of the Board of *Directors / Members / Partners of:

_____ (legally correct full name and registration number, if applicable, of the Enterprise)

Held at _____ (place)

on _____ (date)

RESOLVED that:

1. The Enterprise submits a Tender, in consortium/joint venture with the following Enterprises:

_____ (list all the legally correct full names and registration numbers, if applicable, of the Enterprises forming the consortium/joint venture)

to the Department of Public Works in respect of the following project:

_____ (project description as per Tender Document)

Tender Number: _____ (Tender Number as per Tender Document)

- 1 *Mr/Mrs/Ms: _____

in *his/her Capacity as: _____ (Position in the Enterprise)

and who will sign as follows:

be, and is hereby, authorised to sign a consortium/joint venture agreement with the parties listed under item 1 above, and any and all other documents and/or correspondence in connection with and relating to the consortium/joint venture, in respect of the project described under item 1 above.

- 2 The Enterprise accept joint and several liability with the parties listed under item 1 above for the due fulfilment of the obligations of the joint venture deriving from, and in any way connected with, the Contract to be entered into with the Department in respect of the project described under item 1 above.
- 3 The Enterprise chooses as its *domicilium citandi et executandi* for all purposes arising from this joint venture agreement and the Contract with the Department in respect of the project under item 1 above:

Physical address: _____

_____ (code)

Postal Address: _____

 _____ (code)

Telephone number: _____ Fax number: _____

	Name	Capacity	Signature
1			
2			
3			
4			
5			
6			
7			
8			
9			
10			

The tendering enterprise hereby absolves the Department of Public Works from any liability whatsoever that may arise as a result of this document being signed.

Note:

- * Delete which is not applicable.
- NB:** This resolution must, where possible, be signed by all the Directors / Members / Partners of the Tendering Enterprise.
- In the event that paragraph 2 cannot be complied with, the resolution must be signed by Directors / Members / Partners holding a majority of the shares / ownership of the Tendering Enterprise (attach proof of shareholding / ownership hereto).
- Directors / Members / Partners of the Tendering Enterprise may alternatively appoint a person to sign this document on behalf of the Tendering Enterprise, which person must be so authorized by way of a duly completed power of attorney, signed by the Directors / Members / Partners holding a majority of the shares / ownership of the Tendering Enterprise (proof of shareholding / ownership and power of attorney are to be attached hereto).
- Should the number of Directors / Members / Partners exceed the space available above, additional names and signatures must be supplied on a separate page.

ENTERPRISE STAMP

PA-15.3: SPECIAL RESOLUTION OF CONSORTIA OR JOINT VENTURES

RESOLUTION of a meeting of the duly authorised representatives of the following legal entities who have entered into a consortium/joint venture to jointly tender for the project mentioned below: *(legally correct full names and registration numbers, if applicable, of the Enterprises forming a consortium/joint venture)*

1 _____

2 _____

3 _____

4 _____

5 _____

6 _____

7 _____

8 _____

Held at _____ *(place)*

on _____ *(date)*

RESOLVED that:

A. The above-mentioned Enterprises submit a tender in consortium/joint venture to the Department of Public Works & Infrastructure in respect of the following project:

(project description as per Tender Document)

Tender Number: _____ *(tender number as per Tender Document)*

B. Mr/Mrs/Ms: _____
in *his/her Capacity as: _____ (position in the Enterprise)
and who will sign as follows: _____

be, and is hereby, authorised to sign the tender, and any and all other documents and/or correspondence in connection with and relating to the tender, as well as to sign any Contract, and any and all documentation, resulting from the award of the tender to the Enterprises in consortium/joint venture mentioned above.

C. The Enterprises constituting the consortium/joint venture, notwithstanding its composition, shall conduct all business under the name and style of:

D. The Enterprises to the consortium/joint venture accept joint and several liability for the due fulfilment of the obligations of the consortium/joint venture deriving from, and in any way connected with, the Contract entered into with the Department in respect of the project described under item A above.

E. Any of the Enterprises to the consortium/joint venture intending to terminate the consortium/joint venture agreement, for whatever reason, shall give the Department 30 days' written notice of such intention. Notwithstanding such decision to terminate, the Enterprises shall remain jointly and severally liable to the Department for the due fulfilment of the obligations of the consortium/joint venture as mentioned under item D above.

F. No Enterprise to the consortium/joint venture shall, without the prior written consent of the other Enterprises to the consortium/joint venture and of the Department, cede any of its rights or assign any of its obligations under the consortium/joint venture agreement in relation to the Contract with the Department referred to herein.

G. The Enterprises choose as the *domicilium citandi et executandi* of the consortium/joint venture for all purposes arising from the consortium/joint venture agreement and the Contract with the Department in respect of the project under item A above:

Physical address: _____

_____ (code)

Postal Address: _____

_____ (code)

Telephone number _____ Fax number: _____

E-mail address: _____

	Name	Capacity	Signature
1			
2			
3			
4			
5			
6			
7			
8			
9			
10			
11			
12			
13			
14			
15			

The tendering enterprise hereby absolves the Department of Public Works & Infrastructure from any liability whatsoever that may arise as a result of this document being signed.

Note:

1. * Delete which is not applicable.
2. **NB:** This resolution must be signed by all the Duly Authorised Representatives of the Legal Entities to the consortium/joint venture submitting this tender, as named in item 2 of Resolution PA-15.2.
3. Should the number of the Duly Authorised Representatives of the Legal Entities joining forces in this tender exceed the space available above, additional names, capacity and signatures must be supplied on a separate page.
4. Resolution PA-15.2, duly completed and signed, from the separate Enterprises who participate in this consortium/joint venture, must be attached to this Special Resolution (PA-15.3).

PA-16: PREFERENCE POINTS CLAIM FORM IN TERMS OF THE PREFERENTIAL PROCUREMENT REGULATIONS 2017

This preference form must form part of all bids invited. It contains general information and serves as a claim form for preference points for Broad-Based Black Economic Empowerment (B-BBEE) Status Level of Contribution.

NB: BEFORE COMPLETING THIS FORM, BIDDERS MUST STUDY THE GENERAL CONDITIONS, DEFINITIONS AND DIRECTIVES APPLICABLE IN RESPECT OF B-BBEE, AS PRESCRIBED IN THE PREFERENTIAL PROCUREMENT REGULATIONS, 2017 AND THE AMENDED B-BBEE CODES.

1. GENERAL CONDITIONS

1.1 The following preference point systems are applicable to all bids:

- the 80/20 system for requirements with a Rand value of up to R50 000 000 (all applicable taxes included);
and
- the 90/10 system for requirements with a Rand value above R50 000 000 (all applicable taxes included).

1.2 The value of this bid is estimated to **not exceed** R50 000 000 (all applicable taxes included) and therefore the **80/20** points system shall be applicable.

1.3 Preference points for this bid shall be awarded for:

- (a) Price; and
- (b) B-BBEE Status Level of Contribution.

1.3.1 The maximum points for this bid are allocated as follows:

	POINTS
1.3.1.1 PRICE	80
1.3.1.2 B-BBEE STATUS LEVEL OF CONTRIBUTION	20
Total points for Price and B-BBEE must not exceed	100

1.4 Failure on the part of a bidder to fill in and/or to sign this form and submit a B-BBEE Verification Certificate from a Verification Agency accredited by the South African Accreditation System (SANAS) or an Accounting Officer as contemplated in the Close Corporation Act (CCA) together with the bid, will be interpreted to mean that preference points for B-BBEE status level of contribution are not claimed.

1.5 An Exempted Micro Enterprise (EME) is only required to obtain a sworn affidavit or a certificate issued by Companies and intellectual property Commission (CIPC) confirming their annual turnover of R10 Million or less and level of black ownership to claim points.

1.6 Qualifying Small Enterprise (QSE) is only required to obtain a sworn affidavit or a certificate issued by Companies and intellectual property Commission (CIPC) confirming their annual turnover of R10 Million or less and level of black ownership to claim points.

1.7 The purchaser reserves the right to require of a bidder, either before a bid is adjudicated or at any time subsequently, to substantiate any claim in regard to preferences, in any manner required by the purchaser.

2. DEFINITIONS

- (a) **“all applicable taxes”** includes value-added tax, pay as you earn, income tax, unemployment insurance fund contributions and skills development levies;
- (b) **“B-BBEE”** means broad-based black economic empowerment as defined in section 1 of the Broad-Based Black Economic Empowerment Act;
- (c) **“B-BBEE status level of contributor”** means the B-BBEE status received by a measured entity based on its overall performance using the relevant scorecard contained in the Codes of Good Practice on Black Economic Empowerment, issued in terms of section 9(1) of the Broad-Based Black Economic Empowerment Act;
- (d) **“bid”** means a written offer in a prescribed or stipulated form in response to an invitation by an organ of state for the provision of services, works or goods, through price quotations, advertised competitive bidding processes or proposals;
- (e) **“Broad-Based Black Economic Empowerment Act”** means the Broad-Based Black Economic Empowerment Act, 2003 (Act No. 53 of 2003);
- (f) **“comparative price”** means the price after the factors of a non-firm price and all unconditional discounts that can be utilized have been taken into consideration;
- (g) **“consortium or joint venture”** means an association of persons for the purpose of combining their expertise, property, capital, efforts, skill and knowledge in an activity for the execution of a contract;
- (h) **“contract”** means the agreement that results from the acceptance of a bid by an organ of state;
- (i) **“EME”** means an Exempted Micro Enterprise as defines by Codes of Good Practice under section 9 (1) of the Broad-Based Black Economic Empowerment Act, 2003 (Act No. 53 of 2003);
- (j) **“Firm price”** means the price that is only subject to adjustments in accordance with the actual increase or decrease resulting from the change, imposition, or abolition of customs or excise duty and any other duty, levy, or tax, which, in terms of the law or regulation, is binding on the contractor and demonstrably has an influence on the price of any supplies, or the rendering costs of any service, for the execution of the contract;
- (k) **“functionality”** means the measurement according to predetermined norms, as set out in the bid documents, of a service or commodity that is designed to be practical and useful, working or operating, taking into account, among other factors, the quality, reliability, viability and durability of a service and the technical capacity and ability of a bidder;
- (l) **“non-firm prices”** means all prices other than “firm” prices;
- (m) **“person”** includes a juristic person;
- (n) **“QSE”** means a Qualifying Small Enterprise as defines by Codes of Good Practice under section 9 (1) of the Broad-Based Black Economic Empowerment Act, 2003 (Act No. 53 of 2003);
- (o) **“rand value”** means the total estimated value of a contract in South African currency, calculated at the time of bid invitations, and includes all applicable taxes and excise duties;
- (p) **“sub-contract”** means the primary contractor’s assigning, leasing, making out work to, or employing, another person to support such primary contractor in the execution of part of a project in terms of the contract;
- (q) **“total revenue”** bears the same meaning assigned to this expression in the Codes of Good Practice on Black Economic Empowerment, issued in terms of section 9(1) of the Broad-Based Black Economic Empowerment Act and promulgated in the *Government Gazette* on 9 February 2007;
- (r) **“trust”** means the arrangement through which the property of one person is made over or bequeathed to a trustee to administer such property for the benefit of another person; and
- (s) **“trustee”** means any person, including the founder of a trust, to whom property is bequeathed in order for such property to be administered for the benefit of another person.

3. ADJUDICATION USING A POINT SYSTEM

- 3.1 The bidder obtaining the highest number of total points will be awarded the contract.
- 3.2 Preference points shall be calculated after prices have been brought to a comparative basis taking into account all factors of non-firm prices and all unconditional discounts;
- 3.3 Points scored must be rounded off to the nearest 2 decimal places.
- 3.4 In the event that two or more bids have scored equal total points, the successful bid must be the one scoring the highest number of preference points for B-BBEE.
- 3.5 However, when functionality is part of the evaluation process and two or more bids have scored equal points including equal preference points for B-BBEE, the successful bid must be the one scoring the highest score for functionality.
- 3.6 Should two or more bids be equal in all respects, the award shall be decided by the drawing of lots.

4. POINTS AWARDED FOR PRICE

4.1 THE 80/20 OR 90/10 PREFERENCE POINT SYSTEMS

A maximum of 80 or 90 points is allocated for price on the following basis:

$$P_s = 80 \left(1 - \frac{P_t - P_{\min}}{P_{\min}} \right) \quad \text{or} \quad P_s = 90 \left(1 - \frac{P_t - P_{\min}}{P_{\min}} \right)$$

Where

- P_s = Points scored for comparative price of bid under consideration
- P_t = Comparative price of bid under consideration
- P_{\min} = Comparative price of lowest acceptable bid

5. POINTS AWARDED FOR B-BBEE STATUS LEVEL OF CONTRIBUTION

- 5.1 In terms of Regulation 6(2) and /or 7(2), of the Preferential Procurement Regulations, preference points must be awarded to a bidder for attaining the B-BBEE status level of contribution in accordance with the table below:

B-BBEE Status Level of Contributor	Number of points (90/10 system)	Number of points (80/20 system)
1	10	20
2	9	18
3	6	14
4	5	12

5	4	8
6	3	6
7	2	4
8	1	2
Non-compliant contributor	0	0

- 5.2 A trust, consortium or joint venture, will qualify for points for their B-BBEE status level as a legal entity, provided that the entity submits their B-BBEE status level certificate.
- 5.3 A trust, consortium or joint venture will qualify for points for their B-BBEE status level as an unincorporated entity, provided that the entity submits their consolidated B-BBEE scorecard as if they were a group structure and that such a consolidated B-BBEE scorecard is prepared for every separate bid.
- 5.4 Tertiary institutions and public entities will be required to submit their B-BBEE status level certificates in terms of the specialized scorecard contained in the B-BBEE Codes of Good Practice.
- 5.5 A person awarded a contract may not sub-contract more than 25% of the value of the contract to any other enterprise that does not have an equal or higher B-BBEE status level than the person concerned, unless the contract is sub-contracted to an EME that has the capability and ability to execute the sub-contract.

6. BID DECLARATION

- 6.1 Bidders who claim points in respect of B-BBEE Status Level of Contribution must complete the following.

7. B-BBEE STATUS LEVEL OF CONTRIBUTION CLAIMED IN TERMS OF PARAGRAPHS 1.3.1.2 AND 5.1

- 7.1 B-BBEE Status Level of Contribution: = (maximum of 10 or 20 points)

(Points claimed in respect of paragraph 7.1 must be in accordance with the table reflected in paragraph 5.1 and must be substantiated by means of a B-BBEE certificate issued by a Verification Agency accredited by SANAS or Sworn Affidavit for EME's and QSE's.

8. SUB-CONTRACTING (relates to 5.5)

- 8.1 Will any portion of the contract be sub-contracted? YES / NO (delete which is not applicable)

- 8.1.1 If yes, indicate:

- (i) what percentage of the contract will be subcontracted?.....%
- (ii) the name of the sub-contractor?.....
- (iii) the B-BBEE status level of the sub-contractor?.....
- (iv) whether the sub-contractor is an EME/ a QSE? YES / NO (delete which is not applicable)

Designated Group: An EME or QSE which is at least 51% owned by:	EME √	QSE √
Black people		
Black people who are youth		
Black people who are women		
Black people with disabilities		
Black people living in rural or underdeveloped areas or townships		
Cooperative owned by black people		
Black people who are military veterans		
OR		
Any EME		
Any QSE		

9. DECLARATION WITH REGARD TO COMPANY/ FIRM

9.1 Name of company/ firm:

9.2 VAT registration number:

9.3 Company registration number:

9.4 TYPE OF COMPANY/ FIRM
 Partnership/Joint Venture / Consortium
 One person business/sole propriety
 Close corporation
 Company
 (Pty) Limited
 [Tick applicable box]

9.5 DESCRIBE PRINCIPAL BUSINESS ACTIVITIES

.....

9.6 COMPANY CLASSIFICATION

Manufacturer
 Supplier
 Professional service provider
 Other service providers, e.g. transporter, etc.
 [Tick applicable box]

9.7 Total number of years the company/ firm has been in business?

9.8 I/ we, the undersigned, who is/are duly authorised to do so on behalf of the company/ firm, certify that the points claimed, based on the B-BBE status level of contribution indicated in paragraph 7 of the foregoing certificate/ Sworn Affidavit, qualifies the company/ firm for the preference(s) shown and I/ we acknowledge that:

- (i) The information furnished is true and correct;
- (ii) The preference points claimed are in accordance with the General Conditions as indicated in paragraph 1 of this form.
- (iii) In the event of a contract being awarded as a result of points claimed as shown in paragraph

- 7, the contractor may be required to furnish documentary proof to the satisfaction of the purchaser that the claims are correct;
- (iv) If the B-BBEE status level of contribution has been claimed or obtained on a fraudulent basis or any of the conditions of contract have not been fulfilled, the purchaser may, in addition to any other remedy it may have –
- (a) Disqualify the person from the bidding process;
 - (b) Recover costs, losses or damages it has incurred or suffered as a result of that person's conduct;
 - (c) Cancel the contract and claim any damages which it has suffered as a result of having to make less favourable arrangements due to such cancellation;
 - (d) Restrict the bidder or contractor, its shareholders and directors, or only the shareholders and directors who acted on a fraudulent basis, from obtaining business from any organ of state for a period not exceeding 10 years, after the *audi alteram partem* (hear the other side) rule has been applied; and
 - (e) Forward the matter for criminal prosecution

WITNESSES:

1.

2.

.....
SIGNATURE(S) OF BIDDER(S)

DATE:.....

ADDRESS:.....

.....

THIS FORM IS ALIGNED TO SBD 6.1

C1: AGREEMENT AND CONTRACT DATA

C1.1 Form of Offer and Acceptance

Offer

The Employer, identified in the acceptance signature block, has solicited offers to enter into a contract for the procurement of:

PROFESSIONAL ARCHITECTURAL SERVICES

on the Project

DEVELOPMENT OF STANDARD DESIGN GUIDELINES FOR THE SOUTH AFRICAN POLICE SERVICES

The tenderer, identified in the offer signature block, has examined the documents listed in the Tender Data and addenda thereto as listed in the returnable schedules, and by submitting this offer has accepted the conditions of tender.

By the representative of the tenderer, deemed to be duly authorized, signing this part of this form of offer and acceptance, the tenderer offers to perform all of the obligations and liabilities of the Service Provider under the Contract including compliance with all its terms and conditions according to their true intent and meaning for remuneration to be determined in accordance with the conditions of Contract identified in the Contract Data.

The offered price for this service as described in C3 Scope of Services, inclusive of all applicable taxes (“all applicable taxes” includes value- added tax, pay as you earn, income tax, unemployment insurance fund contributions and skills development levies), is:

Rand (in figures) R

Rand (in words).....

.....

The amount in words takes precedence over the amount in figures. The award of the tender may be subjected to price negotiation with the preferred tender(s). The negotiated and agreed price will be considered for acceptance as ***a firm and final offer***.

This offer may be accepted by the Employer by signing the acceptance part of this form of offer and acceptance and returning one copy of this document to the tenderer before the end of the period of validity stated in the Tender Data, whereupon the tenderer becomes the party named as the Service Provider in the conditions of Contract identified in the Contract Data.

THIS OFFER IS MADE BY THE FOLLOWING LEGAL ENTITY: (cross out block which is not applicable)

Company or close corporation:
.....
.....
whose registration number is:
.....
whose income tax reference number is:
.....
and whose National Treasury Central Supplier Database (CSD) numbers are:
CSD supplier number:

Tax Compliance Status Pin (TCSP).....

OR

Natural person or partnership:
.....
.....
whose identity number(s) is/are:
.....
whose income tax reference number is/are:
.....
and whose National Treasury Central Supplier Database (CSD) numbers are:
CSD supplier number:

Tax Compliance Status Pin (TCSP).....

AND WHO IS (if applicable):

Trading under the name and style of:
--

AND WHO IS:

Represented herein, and who is duly authorised to do so, by: Mr/Mrs/Ms: In his/her capacity as:	Note: A resolution / power of attorney, signed by all the directors / members / partners of the legal entity must accompany this offer, authorising the representative to make this offer.
--	---

SIGNED FOR THE TENDERER:

Name of representative	Signature	Date

WITNESSED BY:

Name of witness	Signature	Date

The tenderer elects as its *domicilium citandi et executandi* in the Republic of South Africa, where any and all legal notices may be served, as (physical address):

.....

.....

Other contact details of the Tenderer are:

Telephone no: Cellular phone no:

Fax no:

Postal address:

E-mail address:

Banker: Branch:

Acceptance

By signing this part of this form of offer and acceptance, the Employer identified below accepts the tenderer's offer. In consideration thereof, the Employer shall pay the Service Provider the amount due in accordance with the conditions of Contract identified in the Contract Data. Acceptance of the tenderer's offer shall form an agreement between the Employer and the tenderer upon the terms and conditions contained in this agreement and in the Contract that is the subject of this agreement.

The terms of the Contract are contained in:

- Part C1 Agreements and Contract Data, (which includes this agreement)
- Part C2 Pricing Data
- Part C3 Scope of Services

and drawings and documents or parts thereof, which may be incorporated by reference into Parts C1 to C3 above.

Deviations from and amendments to the documents listed in the Tender Data and any addenda thereto as listed in the tender schedules as well as any changes to the terms of the offer agreed by the tenderer and the Employer during this process of offer and acceptance, are contained in the schedule of deviations attached to and forming part of this agreement. No amendments to or deviations from set documents are valid unless contained in this schedule.

The tenderer shall within two weeks after receiving a completed copy of this agreement, including the schedule of deviations (if any), contact the Employer's agent (whose details are given in the Contract Data) to arrange the delivery of any bonds, guarantees, proof of insurance and any other documentation to be provided in terms of the conditions of Contract identified in the Contract Data. Failure to fulfil any of these obligations in accordance with those terms shall constitute a repudiation of this agreement.

Notwithstanding anything contained herein, this agreement comes into effect, if sent by registered post, 4 days from the date on which it was posted, if delivered by hand, on the day of delivery, provided that it has been delivered during ordinary business hours, or if sent by fax, the first business day following the day on which it was faxed. Unless the tenderer (now Service Provider) within seven working days of the date of such submission notifies the Employer in writing of any reason why he cannot accept the contents of this agreement, this agreement shall constitute a binding contract between the Parties.

For the Employer:

Name of signatory	Signature	Date

Name of Organisation:	Department of Public Works and Infrastructure
Address of organisation:	

Witnessed by:

Name of witness	Signature	Date

Schedule of Deviations

Notes:

1. The extent of deviations from the tender documents issued by the Employer before the tender closing date is limited to those permitted in terms of the conditions of tender.
2. A tenderer's covering letter shall not be included in the final Contract document. Should any matter in such letter, which constitutes a deviation as aforesaid, become the subject of agreements reached during the process of offer and acceptance, the outcome of such agreement shall be recorded here.
3. Any other matter arising from the process of offer and acceptance either as a confirmation, clarification or change to the tender documents and which it is agreed by the Parties becomes an obligation of the Contract shall also be recorded here.
4. Any change or addition to the tender documents arising from the above agreements and recorded here, shall also be incorporated into the final draft of the Contract.

1.2.1. Subject:
Detail:

1.2.2. Subject:
Detail:

1.2.3. Subject:
Detail:

1.2.4. Subject:
Detail:

1.2.5. Subject:
Detail:

1.2.6. Subject:
Detail:

By the duly authorised representatives signing this agreement, the Employer and the tenderer agree to and accept the foregoing schedule of deviations as the only deviations from and amendments to the documents listed in the Tender Data and addenda thereto as listed in the tender schedules, as well as any confirmation, clarification or changes to the terms of the offer agreed by the tenderer and the Employer during this process of offer and acceptance.

It is expressly agreed that no other matter whether in writing, oral communication or implied during the period between the issue of the tender documents and the receipt by the tenderer of a completed signed copy of this Agreement shall have any meaning or effect in the Contract between the Parties arising from this agreement.

C1.2 Contract Data

C1.2.1 Standard Professional Services Contract
The conditions applicable to this Contract are the **Standard Professional Services Contract (July 2009)** published by the **Construction Industry Development Board (CIDB)**.

The Standard Professional Service Contract is not included in this tender document. Tenderers must obtain it on the CIDB's Website at:
http://www.cidb.org.za/procurement/procurement_toolbox/cidb_pub/default.aspx

C1.2.2 Data provided by the Employer

Clause	
1	<p>Contract Data</p> <p>Specific data, which together with these General Conditions of Contract, collectively describe the risks, liabilities and obligations of the contracting Parties and the procedures for the administration of the Contract. Clauses stipulated in the Contract Data are in addition to or amendments to or replace the corresponding clauses in the STANDARD PROFESSIONAL SERVICES CONTRACT (July 2009) (Third Edition of CIDB document 1014).</p> <p>The Contract Data shall have precedence in the interpretation of any ambiguity or inconsistency between it and the General Conditions of Contract.</p> <p>The General Conditions of Contract in the Standard Professional Services Contract (July 2009) make several references to the Contract Data for details that apply specifically to this tender.</p>
1	<p>Period of Performance</p> <p>The Period of Performance is the period commencing from the date of signature of the letter of acceptance until the Service Provider has completed all Deliverables in accordance with the Scope of Services and in accordance with the approved baseline programme or within the approved extended programme as per Clause 3.15 of the Standard Professional Services Contract (July 2009).</p>
3.4.1	<p>Replace Clause 3.4.1 with the following:</p> <p>Any notice, request, consent, approvals or other communication made between the Parties pursuant to the Contract shall be in writing and forwarded to the address specified in the Contract Data. Such communication shall be deemed to have been made when delivered in person to an authorized representative of the Party to whom the communication is addressed, or one week after having been sent by registered post, or unless otherwise indicated in the Contract Data. Communication by e-mail is permitted but the originals of all contractual documents must be submitted. Email communication shall be deemed to have been delivered to the recipient one calendar day after sending.</p>
3.5	<p>Add to clause 3.5</p> <p>The Services shall be executed in the Service Provider's own office and/or on the Project site as described in C3.2.2 Project description. No portion of the work may be performed by a person employed by the State. No portion of the work may be sublet to any other person or persons without the prior written approval of the Employer.</p>
3.6	<p>Omit the following: "... within two (2) years of completion of the Service ...".</p>
3.8.2	<p>Add the following to clause 3.8.2:</p> <p>The cost of preparation so negotiated shall not exceed the hourly tariff for time based fees as published at the time of the Employer's instruction and the hours will be as negotiated for each Category as defined in C2.1.3.2.</p>

	<p>The cost, for incorporation into the Contract any variations to the Services as ordered by the Employer, shall be calculated according to the Service Provider's tendered price. Implementation of the variation in services to be rendered by the Service Provider, shall only proceed after a written agreement between the parties.</p>
3.9.1 (a)	<p>Replace clause 3.9.1 (a) with the following:</p> <p>A change in legislation takes place in accordance with the provisions of Clause 3.2 provided the change in legislation came into effect after the completion of the tender documentation approved by the Employer.</p>
3.9.1. (c)	<p>Replace "Employers or others" with "the Employer, its employees or clients and/or their agents" Only extension of time without cost will considered in case where a 3rd party has caused a delay.</p>
3.9.1 (d)	<p>No Clause.</p>
3.9.1 (e)	<p>Replace clause 3.9.1 (e) with the following:</p> <p>The contract is restarted following a suspension period of 2 years the Service Provider is entitled to a change in contract price based on the applicable fee scales as published at the time of uplifting the suspension. The applicable fee scales as published at the time of uplifting the suspension will only be applied to the remaining work stages following the suspension.</p>
3.9.3	<p>Replace clause 3.9.3 with the following:</p> <p>"Upon receiving an application from the Service Provider to amend the period of performance and/or fees, the Employer shall assess the changes to the Contract Price and/or extension of the Period of Performance on the impact of the delay on the Services based on the fee structure that the Service Provider has tendered for and appointed on.</p> <p>Additional Services ordered by the Employer shall be assessed on time-based fees as tendered for and adjusted in terms of price adjustment to time-based fees for inflation as per 3.16.</p>
3.9.4	<p>Add to clause 3.9.4:</p> <p>The application for changes to the Period of Performance is subject to the delay being on the Critical Path of the approved programme and due to no fault of the Service Provider.</p>
3.12	<p>Penalty</p> <p>Replace clauses 3.12.1 and 3.12.2 with the following:</p> <p>Period of Performance shall be sub dividable in separate target dates according to the programme for each assignment to be submitted in terms of clause 3.15 hereof.</p> <p>Without prejudice to his other remedies under the Contract or in law, the Employer shall have the right to recover all cost claimed by the contractor in the event that the contractor claimed for delays resulting from actions or non-actions of the Service Provider.</p> <p>The Employer shall further have the right to recover all other cost, including but not restricted to extended rental cost resulting from the delay caused directly or indirectly by the Service Provider, certifying incorrect work for payment, delay in the construction period, remedial cost to correct incorrect designs and or documentation, including omissions.</p> <p>Without prejudice to his other remedies under the Contract or in law, the Employer shall recover a penalty amount per day, stipulated in the table below per target date for the full period of the delay.</p>

In the event that the delay exceeds 30 days, the Employer will have the option to either:

- (i) terminate the contract and recover any loss as a result of the termination from the Service Provider, or
- (ii) allow the Service Provider to continue with the Services after the agreement of a new target date and recover the penalty per calendar day, as stipulated in the table below for the full period of the delay.

CALCULATION OF PENALTIES

VALUE OF FEES				% PENALTIES OF FEES	
1	1	UP TO	500,000	0.05000000	%
2	500,001	UP TO	1,000,000	0.05000000	%
3	1,000,001	UP TO	2,000,000	0.03750000	%
4	2,000,001	UP TO	4,000,000	0.02500000	%
5	4,000,001	UP TO	8,000,000	0.01875000	%
6	8,000,001	UP TO	16,000,000	0.01250000	%
7	16,000,001	UP TO	32,000,000	0.00781250	%
8	32,000,001	UP TO	64,000,000	0.00468750	%
9	64,000,001	UP TO	128,000,000	0.00273438	%
10	128,000,001	UP TO	256,000,000	0.00156250	%
11	256,000,001	UP TO	512,000,000	0.00087891	%
12	512,000,001		and above	0.00048828	%

Recovering of cost and or penalties may be done in the following ways:

- a) claim against professional indemnity insurance, or
- b) deduction from fee account, or
- c) direct payment to the contractor by the consultant, or
- d) litigation, or
- e) any other method available to the Employer

3.15.1

Replace clause 3.15.1 with the following:

A baseline programme for the performance of the Service shall be submitted by the Service Provider, identified as the principal agent in terms of C3.5.1 Service Providers, to the departmental project manager, within a period of two (2) weeks following the briefing meeting and whenever a programme is amended or revised, submit for the Employer's approval a programme for the performance of the Services which shall, inter alia, include:

- a) the order and timing of operations by the Service Provider and any actions, access to people, places and things and work required of the Employer and Others;
- b) the dates by which the Service Provider plans to complete work needed to allow the Employer and Others to undertake work required of them;
- c) provisions for float;
- d) the planned completion of the Services or part thereof in relation to a Period of Performance; and
- e) other information as required in terms of the Scope of Work or Contract Data.

The baseline programme will be the result of the co-ordination of all appointed Service Providers' inputs and shall be in sufficient detail describing key milestones, events and activities linked to the fastest realistic timeframes in which the Service can be delivered. Milestones and events are to be listed based on the Scope of Services described in part C3 of the various appointed Service Providers' tender documents and presented in bar chart format. No milestones may, at the co-

	<p>ordination stage, be extended beyond the timeframes outlined in C3.2.2.3 Project Programme, unless approved by the Employer. The programme thus compiled and presented by the principal agent must be counter-signed by all appointed Service Providers as proof that the programme was agreed upon by all during the said co-ordination action. Such signed programme shall then constitute the Service Contract Period between the Employer and all the appointed Service Providers.</p> <p>In the event of the Employer not being satisfied with the submitted programme, the Parties will negotiate in good faith towards a programme that will be agreeable to both. Such an agreed-upon programme will form the basis for the management of the appointment, the Period of Performance and remuneration purposes of the respective Service Provider/s. Should circumstances change from the initial briefing, the Service Provider/s and the Employer will negotiate a revised programme to satisfy such change(s). Should the Parties fail to reach agreement on the programme or revised programme, the matter will be dealt with in terms of clause 12.1.2 of the General Conditions of Contract. Should the mediation process fail, the Contract will be deemed to have been mutually terminated and any reasonable fees accrued at that stage settled by the Employer.</p> <p>Any failure to comply with the provisions of clause 3.15.1 <i>supra</i> and submit or re-submit the programmes of works or failure to submit the programme on the date required by the Employer, which request shall at all material times be reasonable and fair, shall constitute a material breach of the terms and condition of contract which entitles the Employer to terminate the contract with due regard to clause 8.4 (cidb Standard Professional Services Contract, July 2009).</p>
3.16.2	<p>The adjustment to the time-based fees shall be equal to:</p> $\frac{(CPI_n - CPI_s)}{CPI_s}$ <p>where CPI_s = the indices specified in the Contract Data during the month in which the start date falls CPI_n = the latest indices specified in Contract Data during the month in which the anniversary of the Start Date falls</p> <p>Where CPI_s = the index of StatsSA P0141 (Table B) for the month during which the tender closed. CPI_n = the index of StatsSA P0141 (Table B) for the month in which the anniversary of the tender date falls.</p> <p>The indices of StatsSA P0141 are available on the Website: http://www.statssa.gov.za/Publications/statsdownload.asp?PPN=P0141</p> <p>The formula for calculating the adjusted hourly rate will be:</p> $(((CPI_n - CPI_s) / CPI_s) \times \text{original hourly rate}) + \text{original hourly rate}$
4.1.1	<p>Add to clause 4.1.1 the following:</p> <p>Briefing meeting: The departmental project manager shall arrange a briefing meeting, compulsory for all appointed Service Providers, as soon as practicable after the appointment of the professional team as referred to in C3.5.1 Service Providers, or after the appointment of the core members of the professional team required to commence with the Services if not appointed at the same time, during which meeting the departmental project manager, together with any supporting advisors, will verbally brief the professional team comprehensively regarding the requirements of the project and the Scope of Services and hand over, to the Service Provider/s, all documentation relevant to the execution of the Service.</p>
4.4	<p>Others providing Services on this Project are as listed in C3.5.1 Service Providers.</p>

5.4.1	<p>Add to clause 5.4.1:</p> <p>Minimum professional insurance cover as more comprehensively described in C1.2.3 Data provided by the Service Provider and in respect of which the Service Provider must provide proof of insurance as required.</p>
5.5	<p>Replace clause 5.5 with the following:</p> <p>The Service-Provider is required to obtain the Employer's prior approval in writing before taking, inter alia, any of the following actions:</p> <ol style="list-style-type: none"> a) appointing Subcontractors for the performance of any part of the Services; b) appointing Key Persons not listed by name in the Contract Data; c) travelling for which payment will be claimed, as defined in C2.1.6 Travelling and subsistence arrangements and tariffs of charges; d) deviate from the programme for each assignment; e) deviate from or change the Scope of Services; f) change Key Personnel on the Service; <p>Add to clause 5.5 c:</p> <ol style="list-style-type: none"> 1 Exclusion of authority/powers The Service Provider's authority to act and/or to execute functions or duties is excluded in respect of the matters listed below. The Employer shall retain its powers and authority as stipulated in the applicable clauses of the contract data which are relevant and applicable to the JBCC or GCC conditions of contract. <ol style="list-style-type: none"> 1.1 Nomination of nominated or selected subcontractors; 1.2 Granting of extension of time and/or ruling on claims associated with claims for extension of time; 1.3 Acceleration of the rate of progress and determination of the cost for payment of such acceleration; 1.4 Rulings on claims and disputes; 1.5 Suspension of the works; 1.6 Final payment certificate; 1.7 Issuing of <i>mora</i> notices to the contractor; 1.8 Cancellation of the contract between the Employer and contractor. <p>Any claims, demands, notices, notifications, updated particulars and reports in writing, together with additional supporting documentation pertaining thereto, must be submitted by the contractor to the Service Provider, acting as principal agent, in respect of any of the matters listed in 1.1 to 1.8 above. This must be done within the time periods and in the format(s) as determined in the said/relevant conditions of contract. On receipt thereof, said Service Provider must study the documentation, obtain comments/advice/recommendations from the professional team members and submit a motivated recommendation to the Employer. This must be done timeously as to allow the Employer sufficient time to respond within the time periods and in the format(s) determined in said conditions of contract. The Employer's ruling will be copied to the Service Provider for information.</p> 2 Limitation of authority/powers The Service Provider's authority is limited in respect of the submission to the Employer of comments/recommendations/reports for prior endorsement/approval and further instructions. These pertain to any decision in respect of approval for/of: <ol style="list-style-type: none"> 2.1 Institution of or opposing litigation; 2.2 Issuing of variation orders/contract instructions/orders in writing which increase the value of the works/contract value and/or change the design of intended use of the project; 2.3 Instructions to embark on dayworks; 2.4 Dayworks rates; 2.5 Material quotes relating to dayworks; 2.6 Adjustment of general items relating to dayworks; 2.7 Expenditure on prime cost items;

	<p>2.8 Issuing of practical completion, completion, works completion, final completion and/or final approval certificates.</p> <p>In respect of the matters listed in 2.1 to 2.8 above, the Service Provider must submit all necessary documentation in order to enable the Employer to formulate decisions and to obtain the Employer's formal endorsement/approval prior to acting and/or executing functions or duties in respect of the contract between the Employer and the contractor. This must be done timeously so as to allow the Employer sufficient time for decision-making in terms of the said conditions of contract.</p> <p>Failure to adhere to the above stipulation will cause the Service Provider to be liable in terms of the Contract between Service Provider and Employer for all such unintended costs and damages.</p>
5.8	<p>Add clause 5.8:</p> <p>The Service Providers shall finalize their work and complete the first final account were the contractor's contract has been terminated, where after the Service Providers contract shall terminate, unless the Employer elects to retain the services of the Service Provider's.</p>
7.1.1	<p>Replace clause 7.1.1 with the following:</p> <p>The Service Provider shall employ and provide all qualified and experienced Personnel required to perform the Services. Service Provider/s including personnel performing service must be fit and proper persons with positive security screening and South African identity document (south African citizens).</p>
8.1	<p>Replace clause 8.1 with the following:</p> <p>The Service Provider is to commence the performance of each assignment immediately with due diligence after the approval of the PROGRAMME as specified in clause 3.15 above. Failure to comply shall result in penalties in terms of clause 3.12 and / or termination in terms of 8.4.1.</p>
8.2.4	<p>Replace clause 8.2.4 with the following:</p> <p>The Employer shall, within 30 Days of receipt of a detailed request, grant such extension to the Period of Performance as may be justified, either prospectively or retrospectively, if the extension requested is below 20% of the original period of performance, and 60 days if more than 20% of the original period of performance or, inform the Service Provider that he is not entitled to an extension.</p> <p>Should the Service Provider find the decision of the Employer to be unacceptable he shall, nevertheless, abide by such decision in the performance of the Services and the matter shall be dealt with as a dispute in terms of Clause 12 inform the Service Provider that he is not entitled to an extension. Should the Service Provider find the decision of the Employer to be unacceptable he shall, nevertheless, abide by such decision in the performance of the Services and the matter shall be dealt with as a dispute in terms of Clause 12.</p>
8.4.1	<p>Replace clause 8.4.1 with the following:</p> <p>The Employer may terminate the Contract with the Service Provider:</p> <ul style="list-style-type: none"> (a) where the Services are no longer required; (b) where the funding for the Services is no longer available; (c) where the project has been suspended for a period of two (2) years or more; (d) if the Service Provider does not remedy a failure in the performance of his obligations under the Contract within fourteen (14) Days after having been notified thereof, or within any further period as the Employer may have subsequently approved in writing; (e) if the Service Provider becomes insolvent or liquidated; or (f) if, as the result of <i>Force Majeure</i>, the Service Provider is unable to perform a material portion of the Services for a period of not less than sixty (60) Days; (g) should the Service Provider cease to exist or be incapacitated for whatever reasons, the Employer is entitled, if it so elects;

	<p>(h) at its sole discretion, where the Service Provider is not performing Services in accordance with clause 5.1.1;</p> <p>(i) where the Service Provider has engaged in corrupt or fraudulent practices in tendering for the service contract, or in executing the service contract or in managing the construction contract.</p> <p>(j) at its sole discretion, where the Service Provider is in violation of clause 5.1.1.</p>
8.4.3 (c)	<p>Add to clause 8.4.3 (c) the following:</p> <p>The period of suspension under clause 8.5 is not to exceed two (2) years.</p>
8.4.4	<p>Replace clause 8.4.4 with the following:</p> <p>Upon termination of this Contract pursuant to Clauses 8.4.1 or 8.4.3, the Employer shall remunerate the Service Provider in terms of the Contract for Services satisfactorily performed prior to the effective date of termination and reimburse the Service Provider any reasonable cost incident to the prompt and orderly termination of the Contract, except in the case of termination pursuant to events (d) and (e) of Clause 8.4.1.</p>
8.4.6	<p>Add clause 8.4.6:</p> <p>Upon termination of this Contract or any part thereof, a copy of any drawings and documents produced pursuant to the Contract being ended and not previously provided by the Service Provider to the Employer shall be delivered to the Employer by the Service Provider within 7 working days after the date of termination.</p>
8.4.7	<p>Add clause 8.4.7:</p> <p>Any deviation or failure to comply with the provision of clause 8.4.6 supra would entitle the Employer to withhold any payment due to the Service Provider and to invoke any other remedies available in law to enforce compliance therewith.</p>
9.1	<p>Add to clause 9.1:</p> <p>Copyright of documents prepared for the Project shall be vested with the Employer.</p>
10.2	<p>Replace clause 10.2 with the following:</p> <p>An assignment shall be valid only if it is a written agreement between the Employer and Service Provider by which the Service Provider transfers his rights and obligations under the Contract, or part thereof, to others.</p>
10.3	<p>Replace clause 10.3 with the following:</p> <p>The Service Provider shall not, without the prior written consent of the Employer, assign the Contract or any part thereof, or any benefit or interest thereunder.</p>
12.1.2	<p>Interim settlement of disputes is to be by mediation.</p>
12.2.1	<p>Add to clause 12.2.1:</p> <p>In the event that the Parties fail to agree on a mediator, the mediator is to be nominated by the Association of Arbitrators (Southern Africa).</p>
12.3	<p>No Clause.</p>
12.4	<p>No Clause.</p>
12.5	<p>Add Clause 12.5:</p> <p>Final settlement is by litigation.</p>

13.1.3	<p>Replace clause 13.1.3 with the following:</p> <p>All partners in a joint venture or consortium shall carry the same professional indemnity insurance as per clause 5.4.1 of the General Conditions of Contract.</p>
13.4	<p>Replace clause 13.4 with the following:</p> <p>Neither the Employer nor the Service Provider is liable for any loss or damage resulting from any occurrence unless a claim is formally made within 5 years from the date of termination or completion of the Performance Contract.</p>
13.5	<p>Replace clause 13.5 with the following:</p> <p>The amount of compensation is as per Clause 5.4.1.</p>
13.6	No Clause.
14.2	<p>Replace 14.2 clause with the following:</p> <p>Amounts due to the Service Provider shall be paid by the Employer within thirty (30) Days of receipt by him of the relevant invoices and source documents, which are correct in all respects. If the Service Provider does not receive payment by the due date, he shall be entitled to charge interest on the unpaid amount, at the Prescribed Rate of interest as determined by the appropriate Minister at the time when <i>mora</i> interest is charged.</p>
14.4	<p>Replace 14.4 clause with the following:</p> <p>In respect of Services charged for on a time-basis and all other reimbursable expenses the Service Provider shall maintain records in support of such charges and expenses for a period of sixty months after the completion or termination of the Contract. Within this period the Employer may, on not less than 14 Days' notice, require that a reputable and independent firm of accountants, nominated by him at his expense, audit any claims made by the Service Provider for time charges and expenses by attending during normal working hours at the office where the records are maintained.</p>
15	<p>Add to clause 15:</p> <p>In respect of any amount owed by the Service Provider to the Employer, the Service Provider shall pay the Employer interest at the rate as determined by the Minister of Finance, from time to time, in terms of section 80(1)(b) of the Public Finance Management Act, 1999 (Act no1 of 1999).</p>

C1.2.3 Data provided by the Service Provider

Clause	
	Each item of data given below is cross-referenced to the clause in the General Conditions of Contract to which it mainly applies.
1	The Service Provider is the company, close corporation, natural person or partnership named in C1.1 Form of Offer and Acceptance by the tendering Service Provider.
5.3	The authorised and designated representative of the Service Provider is the person named in the resolution PA-15.1, PA-15.2 or PA-15.3 by the tendering Service Provider.

5.4.1

Indemnification of the Employer

I, the undersigned, being duly authorized by the Service Provider, in terms of the completed resolution (PA-15.1, PA-15.2 or PA-15.3)

..... (Name of authorized person)

hereby confirm that the Service Provider known as:

..... (Legal name of entity tendering herein)

tendering on the project:

.....

..... (Name of project as per C1.1 Form of offer and acceptance)

holds professional indemnity insurance cover, from an approved insurer, duly registered with the Finance Services Board, of not less than R1,5 Million at the time of tender.

I shall submit proof of acceptable Professional Indemnity insurance where the minimum insurance cover is R1,5 Million or 15% of the Value of the Work for the applicable discipline, whichever the greater, to the Client Representative within 30 days upon completion of the planning based on the pre-tender estimate, prior to the commencement of construction. The limit of indemnity will remain intact for Each and Every Claim, no matter how many claims are made.

I further confirm that should the professional indemnity insurance, with no knowledge of the Employer, be allowed to lapse at any time or in the event of the Service Provider cancelling such professional indemnity insurance, with no knowledge of the Employer, at any time or if such professional indemnity cover is not sufficient, then the Service Provider, (i) accepts herewith full liability for the due fulfilment of all obligations in respect of this Service; and (ii) hereby indemnifies, and undertakes to keep indemnified, the Employer in respect of all actions, proceedings, liability, claims, damages, costs and expenses in relation to and arising out of the agreement and/or from the aforesaid Service Provider's intentional and/or negligent wrongful acts, errors and/or omissions in its performance on this Contract.

I confirm that the Service Provider undertakes to keep the Employer indemnified, as indicated above, beyond the Final Completion Certificate/Final Certificate by the Employer (whichever is applicable) for a period of five (5) years after the issue of such applicable certificate.

I confirm that the Service Provider renounces the benefit of the *exceptionis non causa debiti, non numeratae pecuniae* and *excussionis* or any other exceptions which may be legally raised against the enforceability of this indemnification.

Notwithstanding the indemnification required above, the Employer reserves the right to claim damages from the Service Provider for this Project where the Service Provider neglects to discharge its obligations in terms of this agreement.

NAME:

CAPACITY:

SIGNATURE:

7.1.2	<p>As an extension of the definitions contained in clause 1 hereof, Key Persons must, for the purposes of this Contract, include one or more of the professionally registered principal(s) of the Service Provider, and/or, one or more professional(s) employed to render professional services, for whom copies of certificates or other documentation clearly proving current professional registration with the relevant council, including registration numbers, must be included with the tender as part of the returnable documentation.</p> <p>The Key Persons and their jobs / functions in relation to the Services are:</p>			
	Name	Principal and/or employed professional(s)	Category of registration	Specific duties
1.				
2.				
3.				
4.				
5.				
6.				
7.				
8.				
9.				
10.				
7.2	A Personnel Schedule is required.			
<p>If the space provided in the table above is not sufficient to describe the specific duties, this space may be utilized for such purpose:</p>				

C2: PRICING DATA

C2.1 Pricing Assumptions

C2.1.1 Basis of remuneration, method of tendering and estimated fees

C2.1.1.1 Professional fees for **Architectural Services** will be paid on a **time basis as specified in clause C2.1.3.**

C2.1.1.2 Tenderers are to tender:

The different rates for the different categories in C2.2.2 Activity Schedule for Time Based Fees, column (a) all as set out below.

C2.1.2 Remuneration for Architectural Services

C2.1.2.1 Professional fees shall be calculated as follows for Services rendered by the Service Provider:

- **The different rates tendered for the different levels in “C2.2.2 Activity Schedule for Time Based Fees”, column (a), multiplied by the actual number of hours spent plus Value Added Tax, all according to the provisions under C2.1.3.**

C2.1.2.2 Reimbursable rates for typing, printing and duplicating work and forwarding charges as set out under C2.1.5 herein will be paid in full, irrespective of the percentage or rates tendered as referred to in C2.1.1.2 and C2.1.2.1 above.

C2.1.2.3 All fee accounts are to be signed by a principal of the Service Provider and submitted in original format, failing which the accounts will be returned. Copies, facsimiles, electronic and other versions of fee accounts will not be considered for payment.

C2.1.2.4 For all Services provided on a time basis, time sheets giving full particulars of the work, date of execution and time duration, should be submitted with each fee account.

C2.1.2.5 Payments to the Service Provider will be made electronically according to the banking details furnished by the Service Provider and verified by the Employer. Any change in such banking details must be communicated to the departmental project manager timeously. Fee accounts, correct in all respects, will be deemed submitted when received by the Employer and settled when electronically processed by the Employer. The Employer reserves the right to dispute the whole account, any item or part of an item at any time and will deal with such case in terms of clause 14.3 of the General Conditions of Contract.

C2.1.2.6 Accounts for Services rendered may be submitted on the successful completion of each stage of work. Interim accounts will only be considered during the construction stage of the works and then not more frequently than quarterly except if otherwise agreed between the authorised and designated representative of the Service Provider and the Employer. Payment of accounts rendered will be subject to the checking thereof by the departmental project manager. The Employer reserves the right to amend the amounts claimed in order to conform to the rates stipulated in this Contract and make payment on the basis of the balance of the account in accordance with clause 14.3 of the General Conditions of Contract.

C2.1.2.7 The cost of all site Personnel, rendering standard services, will be deemed to be included in the applicable fees as stated in C2.1.1.1 above. Should the need for detailed inspections on site during work stage 5 be required, such requirement shall timeously be motivated in the prescribed format and the cost thereof timeously negotiated in advance with the departmental project manager. Failure to adhere hereto may invalidate any claim the Service Provider may have in respect of any Services rendered without such negotiation process, agreement reached and the terms thereof reduced to writing.

C2.1.2.8 All Services relating to the implementation of the works which are to be provided in terms of the Guidelines for the Implementation of Labour-Intensive Infrastructure Projects under the Expanded Public Works Programme (EPWP) are normal services in terms of the 2015 NDPWI - Scope of

Architectural Services and Tariff of Fees. Any changes in the design of the works to incorporate labour-intensive works should not constitute a change in scope or an additional service where the scope of work is framed around such publications.

- C2.1.2.9 Fee accounts shall be submitted in the Employer's prescribed format, if available. Fee account formats are obtainable on the Employer's Website: <http://www.publicworks.gov.za> under "Documents"; "Consultants Guidelines"; item 9.1.

C2.1.3 Time based fees

- C2.1.3.1 Time based fees are calculated by multiplying the hourly rate for the different categories in C2.2.2 Activity Schedule for Time Based Fees, column (a) which is applicable to the Service Provider for professional and any other technical staff employed by the Service Provider, with the actual time spent by such staff in rendering the Services required by the Employer. These various rates will annually be adjusted for inflation as determined by clause 3.16.2 of the Contract, as amended in the Contract Data in C1.2.2. The time based rates applicable at the time of the execution of the work, as adjusted from time to time, may be claimed.

- C2.1.3.2 The various categories (referred to in C2.2.2 Activity Schedule for Time Based Fees) are the categories referred to in categories A to D below.

To determine the time based fee rates, the professional and technical staff concerned are divided into:-

Category A: Expert professional registered architect
in respect of a private consulting practice in architecture, shall mean a top practitioner whose expertise and relevant experience is nationally or internationally recognized and who provides advice at a level of specialization where such advice is recognized as that of an expert.

Category B: Principals
where level of expertise and relevant experience is commensurate with the position, performs work of a conceptual nature in architectural design and development, provides strategic guidance in planning and executing a project and/or carries responsibility for quality management pertaining to a project.

Category C: Registered professional architect
in respect of a private consulting practice in architecture, shall mean all salaried professional staff with adequate expertise and relevant experience performing work of a relevant professional nature and who carry the direct technical responsibility for one or more specific activities related to a project. A person referred to in level A and/or B above may also fall into this level if such a person performs work of a relevant professional nature at this level.

Category D: Other technical Personnel
in respect of a private consulting practice in architecture, shall mean all other salaried technical staff with adequate expertise and relevant experience performing work of a relevant professional nature with direction and control provided by any person contemplated in levels A, B or C above.

The **different rates tendered for the different categories** are all-inclusive, including allowances for overhead charges incurred by the Service Provider as part of normal business operations, including the cost of management, as well as payments to administrative, clerical and secretarial staff used to support professional and technical staff in general and not on a specific project only.

- C2.1.3.4 Professional and technical staff include all staff performing work directly related to the execution of the Services the Service Provider is engaged for by the Employer and excludes all administrative, clerical and secretarial staff used to support professional and technical staff in general and not on a specific project only, but includes the typing of letters, minutes, reports and documents for projects.

C2.1.3.5 Work will be remunerated for at the category in which it falls as defined in C2.1.3.2 above, irrespective of whether the person who in fact executed the work functions at a higher level of responsibility and competence.

C2.1.3.6 Remuneration upon Suspension or Cancellation of the Project prior to commencement of the Construction Project

In the event of the project being suspended or cancelled prior to the commencement of the construction, the fees claimable by the Service Provider will be determined as follows:

The hourly rate for proven time spent (time sheets) on providing professional services on the project, plus cost of all re-imbursements till date of suspension or cancelation of the Project, irrespective during which phase of the project life cycle prior to commencement of construction, the project is suspended or cancelled.

C2.1.3.7 All fees claimable on an hourly basis must be substantiated by a comprehensive time sheet indicating the date, name of person whom rendered the service, description of the service rendered, the number of hours spent in rendering the service, the applicable rate per hour in terms of this agreement and the total amount claimed per incident. The Employer reserves the right to validate the information provided by the Service Provider and will remunerate the Service Provider on what is deemed to be fair and reasonable.

C2.1.3.8 Unless otherwise specifically agreed in writing, remuneration for the time expended on an assignment shall be limited to the specific personnel and corresponding hours stated in the agreed PEP for that assignment.

C2.1.3.9 If the Activity Schedule did not make provision for rendering services on an hourly rate the hourly rate payable will be calculated in terms of the "Rates for Reimbursable Expenses" as amended from time to time, which is obtainable on the Employer's Website: <http://www.publicworks.gov.za/> under "Documents"; "Consultants Guidelines"; item 1.

C2.1.4 Set off

The Employer reserves the right to set off against any amount payable to the Service Provider, any sum which is owing by the Service Provider to the Employer in respect of this or any other project.

C2.1.5 Typing, printing and duplicating work and forwarding charges

C2.1.5.1 Reimbursable rates

The costs of typing, printing and duplicating work in connection with the documentation which must of necessity be done, except those which must in terms of the relevant Manual or other instructions be provided free of charge, shall be reimbursable at rates applicable at the time of the execution of such work. The document "Rates for Reimbursable Expenses" as amended from time to time and referred to below, is obtainable on the Employer's Website: <http://www.publicworks.gov.za/> under "Documents"; "Consultants Guidelines"; item 1.

C2.1.5.2 Typing and duplicating

If the Service Provider cannot undertake the work himself, he may have it done by another service provider which specialises in this type of work and he shall be paid the actual costs incurred upon submission of statements and receipts which have been endorsed by him confirming that the tariff is the most economical for the locality concerned.

If the Service Provider undertakes the work himself, he shall be paid in respect of actual expenses incurred subject to the maximum tariffs per A4 sheet as set out in Table 1 in the "Rates for Reimbursable Expenses".

Typing and duplicating expenses shall only be refunded in respect of the final copies of the following documents namely formal reports, formal soil investigation reports, specifications, feasibility reports, bills of quantities, material lists, minutes of site meetings and final accounts. The cost of printed hard covers shall only be paid in respect of documents which will be made available to the public such as bills of quantities and specifications or where provision of hard covers is specifically approved.

The typing of correspondence, appendices and covering letters are deemed to be included in the value based fees and time base fees paid.

C2.1.5.3 Drawing duplication

- (a) For drawing duplication the standard rate as set out in Table 2 in the "Rates for Reimbursable Expenses" may be claimed **or** may be claimed according to the provisions as in (b) or (c) below.
- (b) If the Service Provider undertakes the duplication of drawings, using his own duplication equipment, he shall be paid the actual cost incurred on condition that it is not higher than the lowest of three quotations of local firms doing drawing duplication in his locality. Such quotations must accompany his account.
- (c) If the Service Provider does not undertake his own drawing duplication, he shall be paid the lowest of three quotations of local firms doing plan printing in his locality. Such quotations must accompany his account.
- (d) Should there not be three firms doing drawing duplication in his locality, it must be mentioned on his account and the available quotation(s) must then accompany the account.

(The cost of providing all polyester negative prints required to form part of the original set of drawings, as-built drawings including computer assisted drawing records for all facets/disciplines involved in the project are included in the tendered fees and will not be reimbursed separately.)

C2.1.5.4 Forwarding charges

- (a) Only the charges in respect of the forwarding of parcels by courier or air freight on special request by the Employer will be refunded, provided that such charges will not be refunded if the request had been made as a result of a delay caused by the Service Provider.
- (b) The cost of postage, facsimile transmissions, telephone calls, e-mails, etc, is deemed to be included in the value based fees and time based fees paid.

C2.1.6 Travelling and subsistence arrangements and tariffs of charges

When the Service Provider is requested in writing by or obtained prior approval in writing from the Employer to attend specific meetings at any of the Employer's offices or any extraordinary meetings on site or elsewhere, he will be remunerated according to the provisions under C2.1.6.1 to C2.1.6.5 herein.

C2.1.6.1 General

The most economical mode of transport is to be used taking into account the cost of transport, subsistence and time. Accounts not rendered in accordance herewith may be reduced to an amount determined by the Employer.

As the tariffs referred to hereunder are adjusted from time to time, accounts must be calculated at the tariff applicable at the time of the expenditure.

Where journeys and resultant costs are in the Employer's opinion related to a Service Provider's malperformance or failure, in terms of this Contract, to properly document or co-ordinate the work or to manage the Contract, no claims for such costs will be considered.

- C2.1.6.2 **Travelling time**
In the case of an appointment on an hourly basis, travelling time will be fully reimbursed. No travelling time will be paid in respect of journeys to DPWI Head Office or the office of the Departmental Project Manager without prior approval in writing.
- C2.1.6.3 **Travelling costs**
Fees for travelling costs are as set out in Table 3 in the "Rates for Reimbursable Expenses".

Travelling costs will be refunded for the full distance covered per return trip measured from the office of the Service Provider appointed.

Compensation for the use of private motor transport will be in accordance with the Government tariff for the relevant engine swept volume, up to a maximum of 3000 cubic centimetres, prescribed from time to time and as set out in Table 3 in the "Rates for Reimbursable Expenses".
- C2.1.6.4 **Hired vehicles**
In cases where use is made of hired vehicles, the most economical sized vehicle available is to be used but compensation shall nevertheless be restricted to the cost of a hired car not exceeding a capacity of 1300 cc. Where use of a special vehicle is essential (e.g. four track or minibus to accommodate more people), prior approval in writing must be obtained from the departmental project manager.
- C2.1.6.5 **Subsistence allowance**
Subsistence costs associated with travelling for this service as tendered under C2.2 Activity Schedule, will annually be adjusted for inflation for the full duration of the Service Contract Period, as determined by clause 3.16.2, of the Contract, as amended in the Contract Data in C1.2.2. The rates claimable are the rates applicable at the time of the execution of the work.

Subsistence cost, associated with travelling undertaken in excess of the original Service Contract Period in terms of 3.15.1 of Contract Data, will be in terms of Tables 4 and 5 in the "Rates for Reimbursable Expenses" as published by the NDPWI from time to time.

Should the daily tariff as set out in Table 4 be inadequate, substantiated actual costs plus a special daily allowance as shown in Table 5 for incidental expenses, may be claimed. It must be noted that claims may only be according to Table 4 or Table 5. Accommodation should be limited to the equivalent of a three-star hotel and no alcoholic beverages or entertainment costs may be claimed for.

Only actual costs are payable in respect of absence from office of less than 24 hours.

C2.2 Activity Schedule

C2.2.1 Activities

C2.2.1.1 The activities shall be as listed under item C3 Scope of Services as required.

C2.2.1.2 The tenderer must make provision for all activities necessary for the execution of the service as set out in **C3 Scope of Services**, which includes **Annexure A (Terms of Reference)** and **completion of Annexure B (Pricing Schedule)**, hereof.

C2.2.1.3 **Annexure B to be completed and rates, hours and totals to be carried over to C2.2.2 Activity Schedule for Time Based Fees**

C2.2.2 Activity Schedule for Time Based Fees

ACTIVITY SCHEDULE FOR TIME BASED FEES

Tenderer's Rates for Time Based Fees				
Level of prof. and tech. architectural staff as defined in C2.1.3.2	(a) Tenderer's rates for Time Based Fees	X	(b) Estimated hours for each category	(a)x(b) Financial Offer by Tenderer for Time Based Fees
Category A	R	X	h	= R (1)
Category B	R	X	h	= R (2)
Category C	R	X	h	= R (3)
Category D	R	X	h	= R (4)
Total Time-based Fees (1+2+3+4)				= R (5)
Appointment of sub-consultants / specialists				
Description	Quantity (hours required)	Unit	Rate per Hour	Value
As direct sub-consultant, to be appointed by the Service Provider, for: Landscape Architect (Category C)		Hours		= R (6)
As direct sub-consultant, to be appointed by the Service Provider, for: Landscape Architect (Category D)		Hours		= R (7)
As direct sub-consultant, to be appointed by the Service Provider, for: Quantity Surveyor (Cat. C)		Hours		= R (8)
As direct sub-consultant, to be appointed by the Service Provider, for: Quantity Surveyor (Cat. D)		Hours		= R (9)
As direct sub-consultant, to be appointed by the Service Provider, for:		Hours		= R (10)

Sustainability Consultant (Cat. C)						
As direct sub-consultant, to be appointed by the Service Provider, for: Sustainability Consultant (Cat. D)		Hours		= R		(11)
As direct sub-consultant, to be appointed by the Service Provider, for: Graphic Designer (Cat. D)		Hours		= R		(12)
As direct sub-consultant, to be appointed by the Service Provider, for: (indicate the sub-consultant required)(If NOT applicable insert "N/A")		Hours		= R		(13)
As direct sub-consultant, to be appointed by the Service Provider, for: (indicate the sub-consultant required)(If NOT applicable insert "N/A")		Hours		= R		(14)
Sub-total Sub-consultants / Specialists (6+7+8+9+10+11+12+13+14)				= R		(15)
Administration of Sub-consultants				= R		(16)
Total Sub-consultants / Specialists (15+16)				R		(17)
Additional Services						
Any other additional services that may be required by Employer.	N/A	Hours	R	= R	N/A	(18)
Supplementary Services						
Administer Targeted Procurement and Contract Participation Goals applicable to the Contractor	N/A	Hours	R	= R	N/A	(19)
Total Additional and Supplementary Services (15+16)				= R	N/A	(20)
Total Travelling Disbursements (Table A below)				R	N/A	(21)
Sub-total of Total time based fees + Total sub-consultants/Specialists + Total additional and supplementary services + Total travelling disbursements (5+17+20+21)				R		(22)
Add VAT @ 15% (15) X current VAT rate				R		(23)

TOTAL FINANCIAL OFFER FOR TIME BASED FEES CARRIED FORWARD TO THE FORM OF OFFER AND ACCEPTANCE (22+23)

R	(24)
---	------

- NOTE:**
1. Total Financial Offer for Value Based Fees **must be carried over to C1.1 Form of Offer and Acceptance as per (24) above**, if this tender is for time-based fees. Failure to carry this amount over to the Form of Offer and Acceptance **will render the Bid Non-responsive** as the Form of Offer **must be fully** completed.
 2. Remuneration for time based appointments will be calculated as determined in C2.1.2 (i.e. for each category: the actual number of hours multiplied by the tendered rates in (a) above).
 3. Supplementary Services: Where applicable, the Service Provider will be remunerated at an hourly rate as tendered (Based on detailed time sheets) for time spent in liaising, coordinating, sourcing and verification of documents submitted by the contractor including related meetings pertaining to and submitting reports as required to the following Targeted Procurement and Contract Participation Goals applicable to the Construction Project which shall include but not be limited to: SMME contract participation, EPWP and NYS labour reporting, the use of Local Material and Content, the cidb B.U.I.L.D. Programme and any other Contract Participation Goals applicable to the construction project. The hourly rate will be adjusted in accordance with Clause 3.16.2 of the cidb Standard Professional Service Contract and Clause 3.16 of the Contract Data.
 4. Time spent on travelling, as well as any other travel related expenses such as travelling costs, subsistence allowance and accommodation is deemed to be included in the Traveling Disbursements per return trip to site as per (21) above.
 5. In the event of a variation in the Service Contract Period which results in additional travelling over and above the allowed number of trips in **Table A**, the additional Traveling will be paid in accordance with the "Rates for Reimbursable Expenses" as amended from time to time and referred to below, is obtainable on the Department's Website: <http://www.publicworks.gov.za/Consultants.asp> or from the Departmental Project Manager. These expenses are reimbursable at rates applicable on the time of the actual execution of the specific service contract.
 6. Bidder to provide detailed breakdown of Travelling Disbursements per return trip to site from place of business:

Table A: Summary of Disbursements Tendered

Item	Description	Rate	X	Factor	X	No. of trips	Total (if not applicable insert "NA")
1.	Traveling cost by car	Per Km R	X	Kms per Trip	X	N/A	R N/A
2.	Subsistence	Per Trip R	X	-	X	N/A	R N/A
3.	Travelling Time as per Clause C2.1.6.2	Per Hour R	X	Hours per Trip	X	N/A	
4.	Other: Specify below (Table B).	R -	X		X	-	R N/A
5.	Total disbursement carried over to Activity Schedule (14)						R N/A

Table B: Other Disbursements (Attach separate sheet if necessary)

Table B only to be completed should the service provider's office be located in a different province and/or the service provider has to travel by air and/or stay over due to the vast distance between the service provider's office and the construction site, in order to attend site visits and meetings (Attach separate sheet if necessary). Any claim by the service provider in absence of rates will not be entertained except if approved by the Employer's representative prior to incurring the cost.

Item	Description	Rate	X	Qty	Total (if not applicable insert "NA")
1.	Travelling by Air	R	X		R N/A
2.	Car Rental	R	X		R N/A
3.	Accommodation	R	X		R N/A
4.		R	X		R
5.		R	X		R
6.		R	X		R
7.		R	X		R
8.	Total carried over to Table A, Item 4				R N/A

C3: SCOPE OF SERVICES

C3.1 Employer's objectives

This tender is for:

A Service Provider performing architectural work developing an architectural design guideline.

C3.2 Description of the Services

C3.2.1 Services

The following architectural Services are required:

Development of a Design Guideline for the planning of Police Stations as further defined hereafter in C3.3 Extent of Services. Should there be any discrepancies between this Tender Document and other departmental documentation, the former shall take precedence.

C3.2.2 Project description

Appointment of a Service Provider to Develop a Design Guideline for the Department of Public Works and Infrastructure to allow for efficient and cost effective designs of Police Stations that can be completed within a short time span.

C3.2.2.1 Scope

The design guideline will describe the type of spaces commonly associated with facilities for **Police Stations in South Africa** and explain the functioning of a police station, resulting in uniformity, better communication, application of departmental priorities, and policies. The design guideline will apply to the design and construction of new buildings, additions, alteration, and repair and renovations to existing infrastructure.

C3.2.2.2 Location of the Project

National- Guideline document

C3.2.2.3 Project Programme

The programme for the execution of the project is dependent on the various approval processes within the Department and a programme with specific time frames can therefore not be provided at tender stage since it will depend on the time frames required by the consultants for completion of the design and documentation based on the final scope of work, as well as approval processes within the Department and other legislative bodies from whom approvals may be required. The final programme will be in accordance with the approved programme in terms of clause 3.15 of the Standard Professional Services Contract and clause 3.15.1 of the Contract Data. The following table depicts provisional project milestone dates envisaged for tendering purposes only:

	Project Milestones	Anticipated Date
1	Appointment of Design Consultants	27 Jan 2023
2	Inception Report, Status Quo Report & Existing policies and guidelines applicable to planning of a police station	10 Febr 2023
3	Operational spatial models, Generic Guidelines, Standard material choices and schedules & Typical layouts	26 May 2023
4	Maintenance Strategy	19 June 2023
5	Checklists	10 July 2023
6	Final Document and other items	14 Aug 2023

C3.2.2.4 Information available from Employer
Refer to Annexure A, Terms of Reference

C3.2.2.5 Reporting Requirements and Approval Procedure
Refer to Annexure A, Terms of Reference

C3.3 Extent of the Services
Refer to Annexure A: Terms of Reference and Annexure B: Pricing Schedule. Annexure B to be completed and included in the tender submission.

C3.4 Use of reasonable skill and care

It will be expected of the Service Provider to apply reasonable skills and due diligence in the execution of the duties stipulated in this document which shall include *inter alia* the following:

Although the Service Provider's documents may be scrutinised by the Employer, this shall in no way relieve him of his professional responsibility for the proper and prompt execution of his duties. The Employer shall also be entitled to have any documentation or calculations verified by Others. In the event of mal performance, default or negligence, the Employer shall have the right to claim compensation or damages and set off such against any amount payable.

C3.5 Co-operation with other services providers

It will be required of the Service Provider to co-operate with the following:

C3.5.1 Other roleplayers, as may be required from time to time, including the client department/end user(s).

C3.6 Brief

C3.6.1 Target dates and times
The Service Provider will be expected throughout to give preference to the execution of the work involved in this commission.

The work of all Service Providers will be co-ordinated by the principal agent/ project leader. All work is to be performed by the persons listed as Key Persons and persons under their supervision and further be executed as described in the Programme according to clause 3.15 of the Contract Data (and/or PEP according to the same clause, if applicable).

C3.6.2 Reporting requirements
Notwithstanding any other requirements as listed elsewhere, the Service Provider shall submit a monthly report indicating progress of the Services.

C3.6.3 Local content
It is the policy of the Employer to give preference to materials and equipment of South African manufacture. The Service Provider is to ensure that, wherever feasible, designs are based on locally manufactured equipment and materials which can meet requirements at competitive prices.

C3.6.4 Design innovation
Given the need for energy efficiency and environmental sustainability in the built environment, each member of the professional team is required, wherever possible and applicable, to demonstrate design innovation in all aspects of the Service towards "green" design solutions. Aspects to be considered and incorporated in all new building and/or maintenance designs are, *inter alia* but not limited to,
(a) sustainable development
e.g. in building form, material choice, construction detailing and methods, recycling ability;
(b) energy efficiency
e.g.

- (i) passive design methods towards energy conservation and consumption: building orientation, exploitation of nature's inherent energy sources),
- (ii) energy efficient solutions and installations for lighting, ventilation, cooling, heating, etc. (e.g. energy efficient light fittings),
- (iii) alternative or renewable energy sources where practical/feasible/economical;
- (c) water conservation/saving/re-use methods; and
- (d) environmental friendliness (e.g. respect for natural habitat, blending of building with site/environment/surrounding fabric, positioning of buildings, consideration of neighbouring sites' access to sun, wind, view, etc.).

C3.6.5 Final disposal of documents

Upon approval and finalisation of the final account of projects it is a requirement that the Service Provider forward to the Employer all documents relating to this service.

C3.7 Reference data

C3.7.1 Refer to Annexure A, Terms of Reference.

C3.8 Applicable legislation and standards

This section applies to legislation emanating from national and provincial governments as well as that of any local authorities in whose area of jurisdiction the subject of the appointment falls and which has a bearing on the activities and facilities under this appointment.

All the applicable legislation, which do not specifically allow discretion in respect of compliance by the State, shall be followed exactly as intended by such legislation regardless of any instructions, verbal or in writing, to the contrary. (Refer *inter alia* to Section 41 of the Occupational Health and Safety Act, 1993 (Act 85 of 1993)).

Should any applicable legislation allow discretion in respect of compliance by the State, it shall be followed exactly as intended by the relevant legislation as if no discretion is allowed until such time as specific instructions in writing are issued to the appointed professional team by the departmental project manager.

The Service Provider undertakes to ensure that his actions and outcome thereof including, but not limited to, the facilities to be affected by the Service shall be in accordance with all relevant legislation and upon delivery, will function as required by said relevant legislation. The Service Provider's actions and the outcome thereof will in no way be detrimental to the health and safety of the occupants or persons present therein or in the vicinity thereof. Similarly it must not be detrimental to any aspects of the environment in its structure or operation if operated as specified in operation manual(s). The relevant legislation meant herein, as amended, consist of *inter alia* the following, but not limited to:

- Architectural Profession Act, 2000 (Act 44 of 2000);
- Atmospheric Pollution Prevention Act, 1965 (Act 45 of 1965);
- Construction Industry Development Board Act, 2000 (Act 38 of 2000);
- Council for the Built Environment Act, 2000 (Act 43 of 2000);
- Electricity Act, 1987 (Act 41 of 1987);
- Environmental Conservation Act, 1989 (Act 73 of 1989);
- Fire Brigade Services Act, 1987 (Act 99 of 1987);
- Local Government Municipal Systems Act, 2000 (Act 32 of 2000), municipal by-laws and any special requirements of the local service supply authority;
- National Building Regulations and Building Standards Act, 1977 (Act 103 of 1977);
- National Environmental Management Act, 1998 (Act 107 of 1998);
- National Heritage Resources Act, 1999 (Act 25 of 1999);
- National Water Act, 1998 (Act 36 of 1998);
- Occupational Health and Safety Act, 1993 (Act 85 of 1993);
- Telecommunications Act, 1996 (Act 103 of 1996);
- Water Services Act, 1997 (Act 108 of 1997) and general authorizations;

- the latest issue of SANS 10142: "Code of Practice for the Wiring of Premises";
- the Regulations of the local Gas Board, where applicable and
- all regulations promulgated under the above Acts.

Although the more salient legislation has been referred to above, the *onus* remains on the Service Provider to adhere to, and apply, any and all Acts and/or Regulations not specifically mentioned in the list above but which will have an effect on the Project.

This will be a continuous process throughout the appointment, which will manifest itself during the following phases:

- development of plans and documentation;
- supervision of any Service Provider under the appointment;
- ensuring compliance of the end product;
- compiling and issuing of Instruction/Operational Manuals indicating *inter alia* what the legal and safety requirements entail for the user(s)/operator(s) of the facilities;
- providing instruction to the intended users/operators.

The Service Provider accepts full and complete responsibility (both contractually and/or in delict) regarding compliance with the Occupational Health and Safety Act, 1993 (Act 85 of 1993) for his acts and omissions as well as those of his employees and indemnifies the Employer against any legal action in this regard.

The Service Provider undertakes to ensure that the requirements of the Occupational Health and Safety Act, 1993 will similarly apply to the agreement with any sub service providers inclusive of indemnifying the Employer against any legal action regarding the actions and/or omissions by them.

C3.9 Access to land/buildings/sites

Access to the land/buildings/sites shall be negotiated in consultation with the departmental project manager.

C3.10 Software application for programming

The Service Provider must avail himself of software to be used in the Project documentation for compatibility with other Service Providers as well as the Employer. Specific requirements for compatibility are specified in the relevant manuals.

C3.11 Security clearance

Confidentiality Agreement to be signed upon appointment.

C3.12 Forms for contract administration

All forms required during contract administration, called PRM forms, are obtainable on the Employer's website at [http://www.publicworks.gov.za/under "Documents"; "Consultants Guidelines";](http://www.publicworks.gov.za/under%20Documents) item 14.

C3.13 Condition to accept unregistered persons with suitable built environment qualifications on secondment

It is an express term of the contract that the Service Provider, after award of tender, accept unregistered, suitably qualified (built environment) persons in his office for the purpose of exposing the latter to the full extent of professional work, or as may be required according to specific circumstances, in order to gain experience which can be presented to the relevant Council for consideration towards professional registration. The secondment of such unregistered persons will be negotiated with the Service Provider in terms of numbers, periods of training and extent of professional work opportunity to be afforded. The conditions of secondment will be the subject of a separate Memorandum of Understanding with the Service Provider which will serve as an annexure hereto. Any secondment arrangements will cease upon the professional registration of

the seconded person or as agreed on and so included in the aforesaid Memorandum of Understanding. The responsibility for salaries of seconded persons will remain with the Employer, but responsibility for operational expenses, necessary for the execution of the work, will vest with the Service Provider, all of which will be dealt with in the Memorandum of Understanding.

C3.14 Submission of monthly Project Execution Plans (PEP)

The Principle Agent will submit monthly an updated Project Execution Plans (PEP) in accordance with DPWI standard proforma, on a date as agreed with the Employer's Representative.

C4: SITE INFORMATION

This contract is not related to a specific site and Services rendered could be associated to various sites throughout the Republic of South Africa.



public works
& infrastructure

Department
Public Works and Infrastructure
REPUBLIC OF SOUTH AFRICA

ANNEXURE A: Terms of Reference

for the appointment of a Service Provider to Develop a Design Guideline for the Department of Public Works and Infrastructure (DPWI) to allow for efficient and cost effective designs of Police Stations that can be completed within a short time span

Working name: SAPS Design Guideline

Copyright © of this work is reserved under the Copyright Act of the Republic of South Africa (No 98 of 1978) and the provisions of the Berne Convention. This work or any part thereof may not be reproduced in any form or by any means without prior permission in writing NDPWI unless in pursuance of the objectives contained herein

APPOINTMENT OF PROFESSIONAL SERVICE PROVIDERS TO DEVELOP A DESIGN GUIDELINE FOR THE PLANNING OF BUILDINGS FOR THE SOUTH AFRICAN POLICE SERVICES

Table of Contents

1.	INTRODUCTION AND EXPLANATION OF THIS SECTION.....	3
2.	PROPOSED FORMAT FOR THE DESIGN GUIDELINE.....	5
3.	DESCRIPTION OF ASPECTS IN THE PROPOSED LIST THAT NEED TO BE ADDRESSED IN THE DESIGN GUIDELINE TABLE OF CONTENT.....	6
3.1	TABLE OF CONTENT	6
3.2	INTRODUCTION.....	6
3.2.1	SCOPE	6
3.2.2	OBJECTIVES.....	6
3.3	BACKGROUND	7
3.4	SYSTEMIC RESPONSE	7
3.5	TYPOLOGY	8
3.6	SPACIAL RELATIONSHIP	17
3.7	SCHEMATIC DIAGRAMS OF FUNCTIONAL REQUIREMENTS	26
3.8	SPATIAL NORMS	28
3.9	SUPPORT AND ADMINISTRATIVE SPACES	28
3.10	LANDSCAPE APPROACH FOR THE SITE	28
3.11	BRANDING AND IDENTITY	29
3.12	FITTINGS AND FINISHES.....	31
3.13	SIGNAGE	35
3.14	ACOUSTIC TREATMENT	38
3.15	BUILDING MANAGEMENT AND SECURITY	38

3.16	MAINTENANCE MANAGEMENT	40
3.17	SUSTAINABILITY AND “GREEN” DESIGN	41
3.18	CHECK LISTS	45
3.19	CONTEXTUAL RESPONSE	47
3.20	APPROACH TO TECHNOLOGY	48
3.21	GLOSSARY	49
3.22	LIST OF ANNEXURES	50
3.23	REFERENCES	50
4.	DELIVERABLES	51
5.	CRITICAL MILESTONES	54
6.	SKILLS REQUIREMENTS	55
7.	FUNCTIONALITY CRITERIA	56
8.	CONCLUSION	57

1. INTRODUCTION AND EXPLANATION OF THIS SECTION

This project aims to achieve the development of a comprehensive design guideline to guide the consultant architect when designing a new/ addition to a Police Station in South Africa or working to upgrade or repair and renovate an existing facility.

To ensure efficient and cost-effective designs that can be completed within a short time period, the National Department of Public Works and Infrastructure has opted to investigate the possibility of standard designs.

Due to a large number of variables and specific needs for a specific location, it would not be possible to compile a complete standard plan for all Police Stations. It is however possible to focus on certain spaces/ areas that are generally grouped and to create a typical layout showing interconnectivity, functioning, finishes, layouts, etc. The design guideline aims to address this requirement.

The design guideline document will assist with understanding different stages of the process towards designing of Police Stations and provide guidelines for each of these stages to explain more clearly what is to be incorporated in the design.

The terms of reference will aim to clarify the scope of works for the design guideline in more detail and set minimum requirements that are to be met in the design guideline.

A list of essential aspects, as indicated in the indicative Table of Content, is proposed for the design guideline, with a description of each aspect, to better explain to the service provider what is required.

This list is not exhaustive and the service provider may add aspects that may be important and relevant. Proposals relating to changed aspects/ headings must be made to the Project Manager.

Reference is also made to some of the relevant policies and guideline documents within National Department of Public Works and Infrastructure (NDPWI), standards of the South African Police Services, and other relevant departments.

2. PROPOSED FORMAT FOR THE DESIGN GUIDELINE

The following headings are to be included in the Design Guide as a minimum requirement:

1. Table of Content
2. Introduction
3. Scope
4. Objectives
5. Background (by Client)
6. Systemic Response
7. Typology
8. Spatial Relationship
9. Schematic Diagrams of Functional Requirements
10. Spatial Norms
11. Support and Administrative Spaces
12. Landscape Approach for the Site
13. Branding and Identity
14. Fittings and Finishes
15. Signage
16. Acoustic Treatment
17. Building Management
18. Maintenance Management
19. Sustainability and “Green” Design
20. Check List
21. Contextual Response
22. Approach to Technology
23. Glossary
24. List of Annexures
25. References

Each one of these items will be discussed in more detail below. Additional headings may be proposed by the Service Provider.

3. DESCRIPTION OF ASPECTS IN THE PROPOSED LIST THAT NEED TO BE ADDRESSED IN THE DESIGN GUIDELINE TABLE OF CONTENT

3.1 TABLE OF CONTENT

The final “Table of Content” is to be compiled by the service provider. Although the list above is indicative, the service provider may add to the list as mentioned above.

3.2 INTRODUCTION

An “Introduction”, including “Scope” and “Objectives”, must be provided, indicating the purpose of the guideline as well as other information deemed necessary by the service provider.

3.2.1 SCOPE

The “Scope” could include amongst others:

The design guideline will describe the type of spaces commonly associated with facilities for Police Stations and explain the functioning of the various areas, resulting in uniformity, better communication, application of departmental priorities and policies.

The design guidelines will apply to the design and construction of new buildings as well as additions and alterations to existing infrastructure.

3.2.2 OBJECTIVES

The “Objectives” could include amongst others:

The design guideline aim to provide a design guide for architects with comment on certain aspects from other disciplines, but from an architectural point of view.

The document will assist in setting a basic standard for all Police Stations to comply with.

The document will set minimum standards for materials, sustainability targets, etc.

The document will describe all major spaces and spatial groupings within a Police Station.

The document will also investigate the existence of standard documentation and reconsider the standards and align to newer technologies where applicable.

3.3 BACKGROUND

The background must be provided in conjunction with the Client.

The primary tasks of *SAPS* are —

- (a) the prevention of crime;
- (b) visible policing;
- (c) attending to complaints;
- (d) providing a service to the public in the community service centre; and
- (e) to perform the duties attached to a community service centre.

Any number of combinations of different services can be combined in the various stations, depending on the client's requirement in the specific targeted area. Each police station has its own unique support areas, layouts, etc. and needs to be addressed in this guideline document.

3.4 SYSTEMIC RESPONSE

The design guideline must address the client needs. The client for this design guideline is the **South African Police Services**.

VISION: To create a safe and secure environment for all people in South Africa.

MISSION: To prevent and combat crime that may threaten the safety and security of any community;

Investigate any crimes threatening the safety and security of any community;

Ensure that offenders are brought to justice; and

Participate in efforts to address the causes of crime.

PRINCIPLES AND VALUES: The Constitution of the Republic of South African, 1996 (Act 108 of 1996) lays down that the South African Police Service has a responsibility to

- Prevent, combat and investigate crime;
- Maintain public order;
- Protect and secure the inhabitants of the Republic and their property; and
- Uphold and enforce the law.
- Create a safe and secure environment for all people in South Africa.
- Prevent anything that may threaten the safety or security of any community.
- Investigate any crimes that threaten the safety or security of any community
- Ensure criminals are brought to justice; and
- Participation in efforts to address the causes of crime.

Further information can be obtained on www.saps.gov.za

3.5 TYPOLOGY

This chapter will highlight the function of a Police station together with specialist staff that will be working in this space. Special requirements may be highlighted.

The following typologies are examples:

3.5.1 Sizes of Police Stations

The various items are to be expanded on to include all types of Police stations together with its respective support areas. The published outcome of the *theoretical human resource requirement* calculation will determine the number of human resources

required (minimum requirements) as well as the job weight of a police station which will inform the level or category of the station commander as depicted in the upper and lower limit contained in the table below:

Station Commander Category Levels			
Rank	Category	Lower Limit	Upper Limit
Captain	A	36	90
Lieutenant Colonel	B	91	180
Colonel	C1	181	360
Brigadier	C2	361	720

3.5.2 Specialist Areas

3.5.2.1 Cell Types

1. Male Cells (Large)
2. Male Cells (Small)
3. Female Cells
4. Juvenile Male cells
5. Juvenile Female Cells
6. Other (Specialised) (LGBT etc.)

General comments:

Cells should have fittings that are tamper proof.

Benches are built in. Vandal proof WHB and WC to be provided.

Standard layouts are available.

Ceilings to be plastered/ exposed concrete.

Areas where inmates can circulate, must not have loose signage, cover plates, carpets, etc. All areas in the cell block are to comply with the SAPS 5-star requirements.

Cell door locks will be provided and installed by SAPS. Timeous notification must occur to ensure no delay in handing over the building once complete.

3.5.2.2 Cell Support Areas

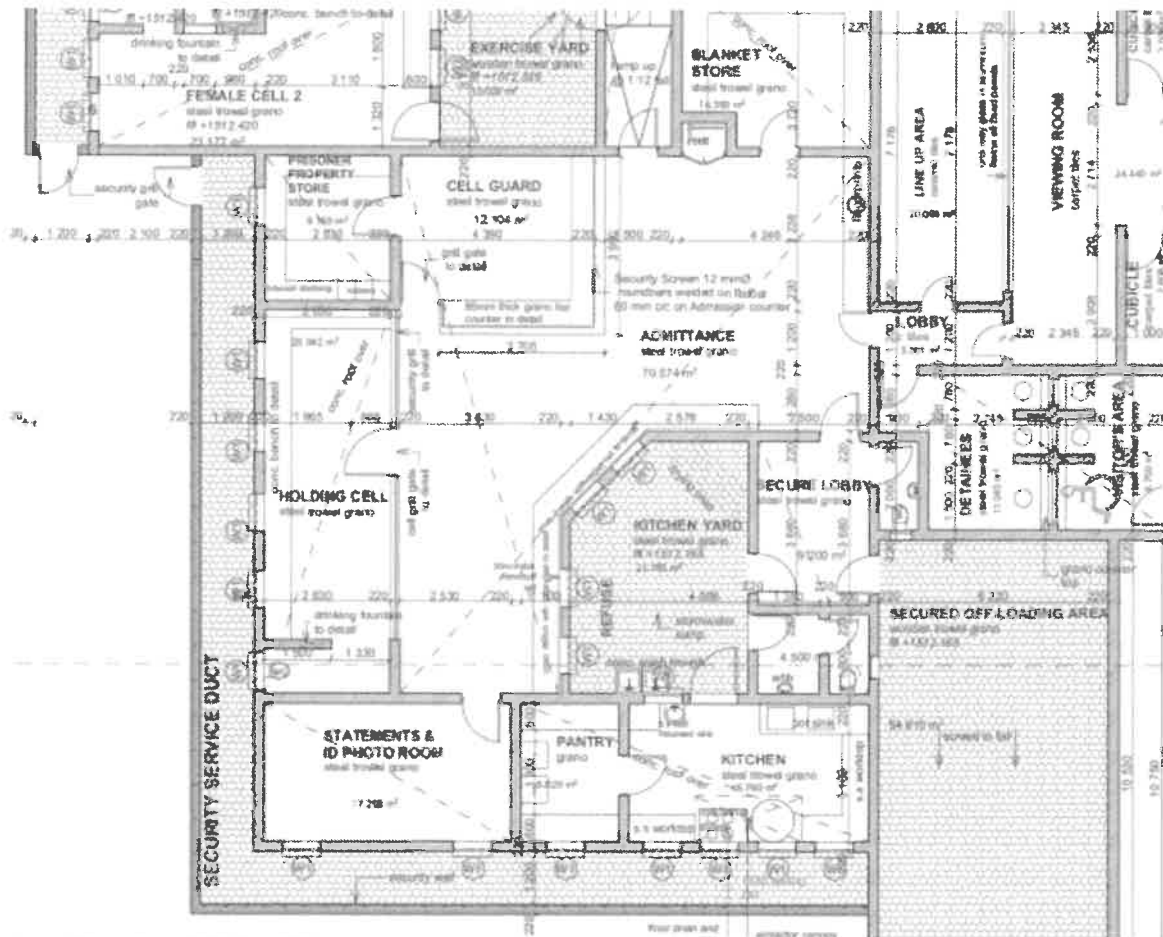

Example of an Admittance Area showing some support areas

Detail to be provided for the following support areas:

- Exercise Yard
- Holding Cell
- Prisoner Property Store

Cell Guard

Pantry

Kitchenette and yard

Admittance

Statement & ID Photo Room

Example of details to be provided for each of the abovementioned areas are mentioned below:

1. Activities in this area
Receiving of accused
Staff working in this area
Special Requirements
2. Officers in this area:
SAPS officials
Accused
3. Special Requirements:
Secure drop off area visible to SAPS officers
Remote closing of gates/ roller shutter doors.
Built in benches with cuff rails.
Fingerprinting area with vandal proof WHB.
Ceilings to be plastered/ exposed concrete.
No loose signage, cover plates, carpets, etc.

All these areas are to be fitted with windows that comply with the SAPS 5-star requirements.

3.5.2.3 SPACES COMMON TO MOST POLICE STATIONS

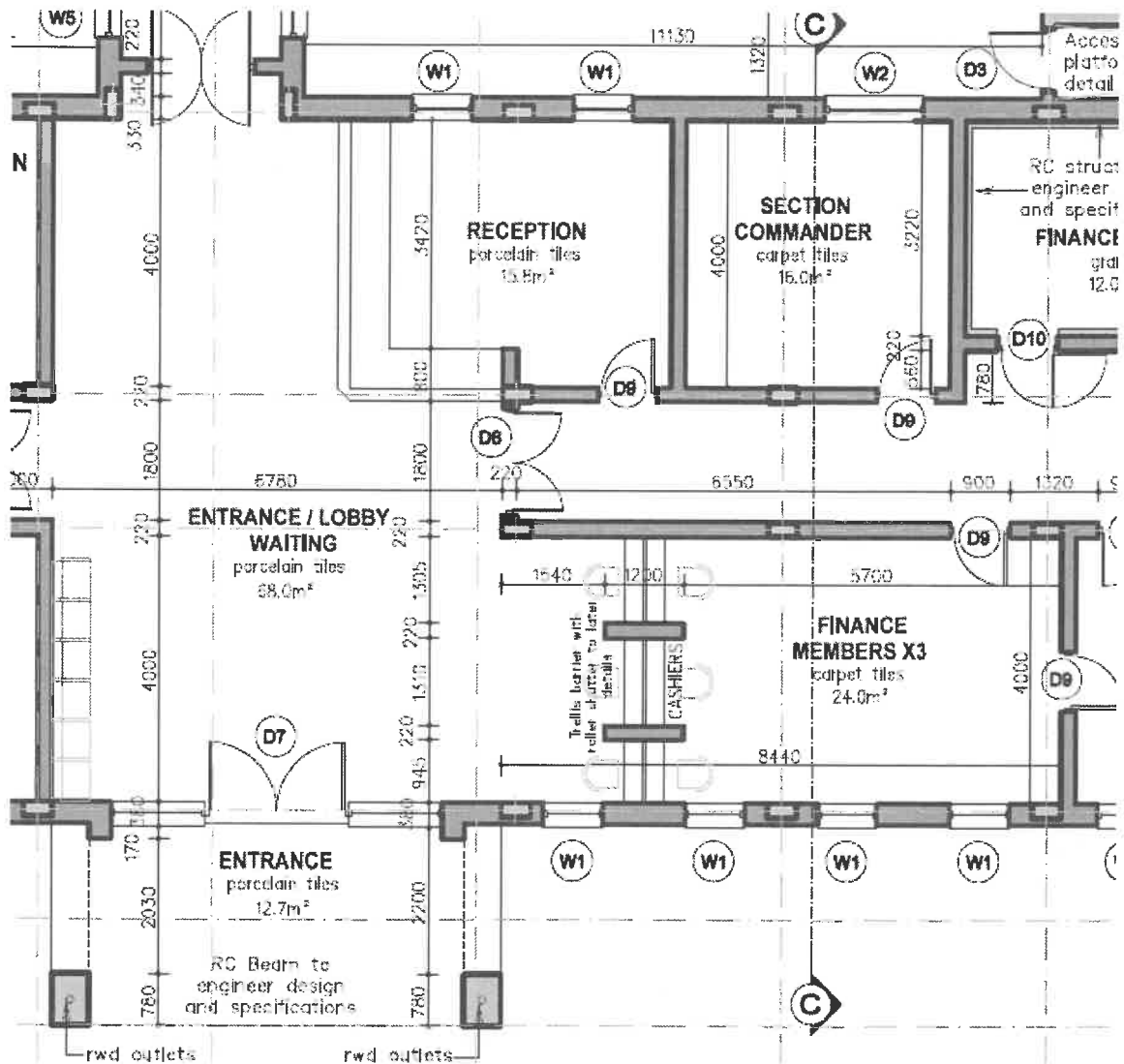

3.5.2.3.1 ENTRANCE

Lobby:

Universal access.

Public Waiting spaces with seating.

3.5.2.3.2 PARKING:

1. Public:

In public zone on the site

Paved area complying with municipal by-laws and SANS 10400.

Paving type

Storm water/ water catchment

Disabled Parking

Pedestrian walkways

2. Government Vehicles:

In Private zone of the site

Garage or enclosed covered areas

3. Staff;

In semi-public zone on the site

Paved area complying with municipal by-laws and SANS 10400.

Paving type

Storm water/ water catchment.

Disabled Parking

Pedestrian walkways

4. Secure drop off areas:

Secure entrance and parking with direct unobstructable access to the secure zone of the building without access to public or other staff.

Size of the delivery truck to be taken into consideration and enough space around the truck to be provided to ensure safe off-loading of the accused.

Remote controlled gate/ door

View panel for SAPS to observe

Vandal proof fittings

Ventilation, etc.

5. **Vehicle Yard**

Private zone
Fencing type
Access control
Storm water management
Road finish
Turning Circles

6. **Large Vehicle Yard**

Private zone
Fencing type
Access control
Storm water management
Road finish
Turning Circles

7. **Wash Bays**

Water Management and recycling opportunities
Paving Type

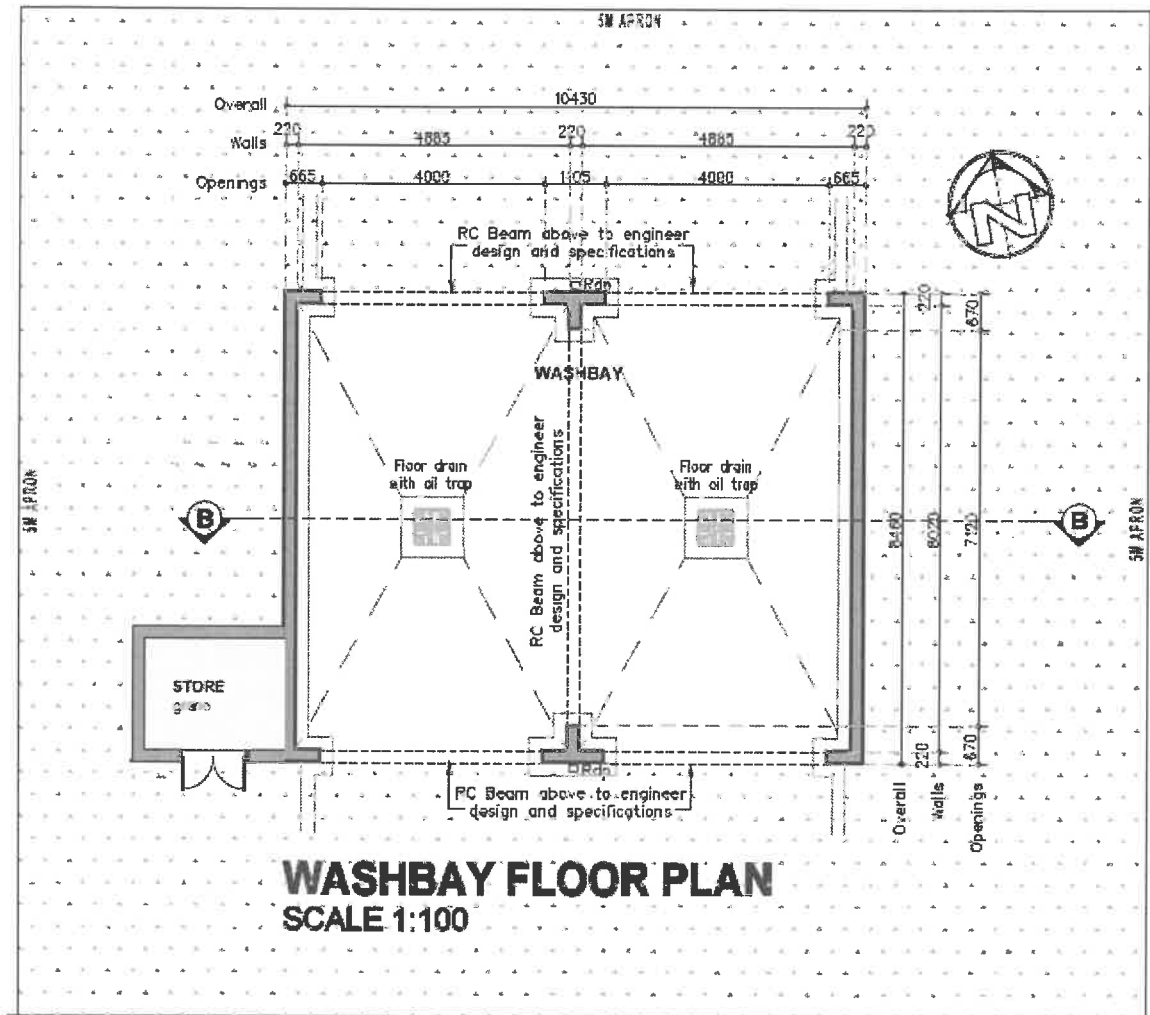

GENERAL NOTES

FOUNDATIONS

- 1.1 Concrete foundation to engineer design and specifications

FLOORS

- 2.1 25mm smooth floated screed on concrete slab on comp proof membrane on blinding layer. All to Engineer specifications
- 2.2 Approved die finish to finishing schedule
- 2.3 Approved floor finish to finishing schedule
- 2.4 Approved ceiling to finishing schedule

WALLS

- 3.1 Internal walls to be smooth plastered, skimmed and sanded. All to finishing schedule
- 3.2 25 Degree lean-splashed plastered external. All waterproofing of all to specialist specifications
- 3.3 Door / Window to schedule
- 3.4 Plaster and paint to finishing schedule
- 3.5 Face brick to finishing schedule

CEILINGS

- 4.1 Gyproc Gypla 6.5mm Omega Flute plastered ceiling with water edged Plastroboard fixed joint side up with 25mm Gyproc Plastroboard Sharp Point Screws at 150mm centres to steel bracing at 300mm centres in one direction. All joints to be covered with Gyproc Plastrobe fixed joint joint (double over butt joints) and then plastered with 3mm to 5mm thick Plastrobe Multipurpose plaster. All fixed to trusses at 1000 centres with 10mm black Anacrite non-combustible light weight glass wool thermal ceiling insulation, nominal density 120 kg/m³ closely fitted with ends butted firmly between the beams and not loose or top of bracing between roof timbers, in accordance with the manufacturer's recommendations.
Omega code: Code 2
R-value: 2.68m²/K
Thermal conductivity: 0.04 W/mK
- 4.2 150mm Glasswool insulation to comply with the requirements in SANS 1540C

ROOFS

- 5.1 0.6mm thick epoxy-resin pre-painted composite chromsteel roof sheeting as per P11 271 issue 1.3.1c1 roof sheeting fixed to 50x70mm S4 pine battens on timber roof trusses to engineer design and specifications. Roof colour to finishing schedule
- 5.2 Seamless copper profile downspout gutter with a 100mm dia round down pipe. Gutter fixed against 50x70mm timber fascia board
- 5.3 Galvalit steel purlin to roof manufacturer specifications

APPOINTMENT OF PROFESSIONAL SERVICE PROVIDERS TO DEVELOP A DESIGN GUIDELINE FOR THE PLANNING OF BUILDINGS FOR THE SOUTH AFRICAN POLICE SERVICES

3.6 SPACIAL RELATIONSHIP

To be read in conjunction with item 3.5 Typology.

Diagrams explaining the relationship between the different spaces are to be developed and provided. E.g. refers to the Cell area and its supporting areas.

Example of Schematic diagram that must be drafted to explain the working of each specialist function as not all facilities provided will be able to always be exactly as designed.

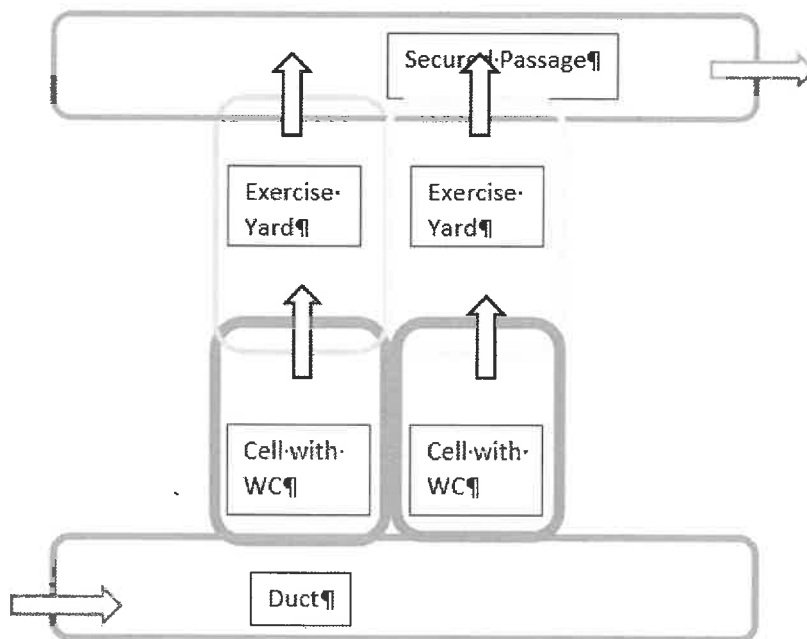

Example of a relationship diagram for a cell

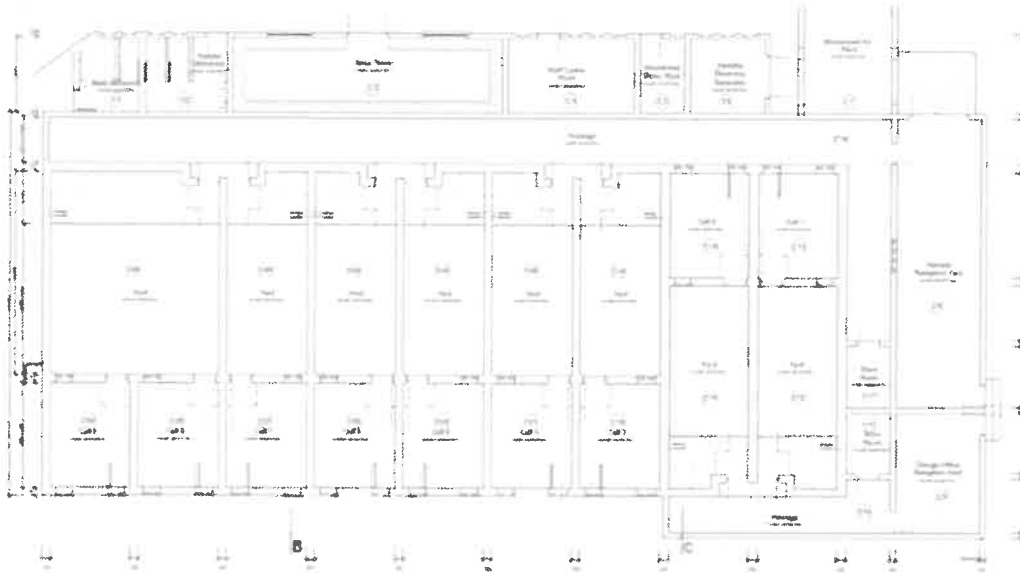

Schematic designs to be developed for various functions. The above example is for the Cell block.

Sample layouts based on the schematic layouts.

Overall layouts will differ based on the design of the police station, site parameters, etc.

This further illustrates sizes compared to the different functions.

The approved Procurement Instruction informs this process.

The Policy of SAPS relating to furniture should be obtained and considered.

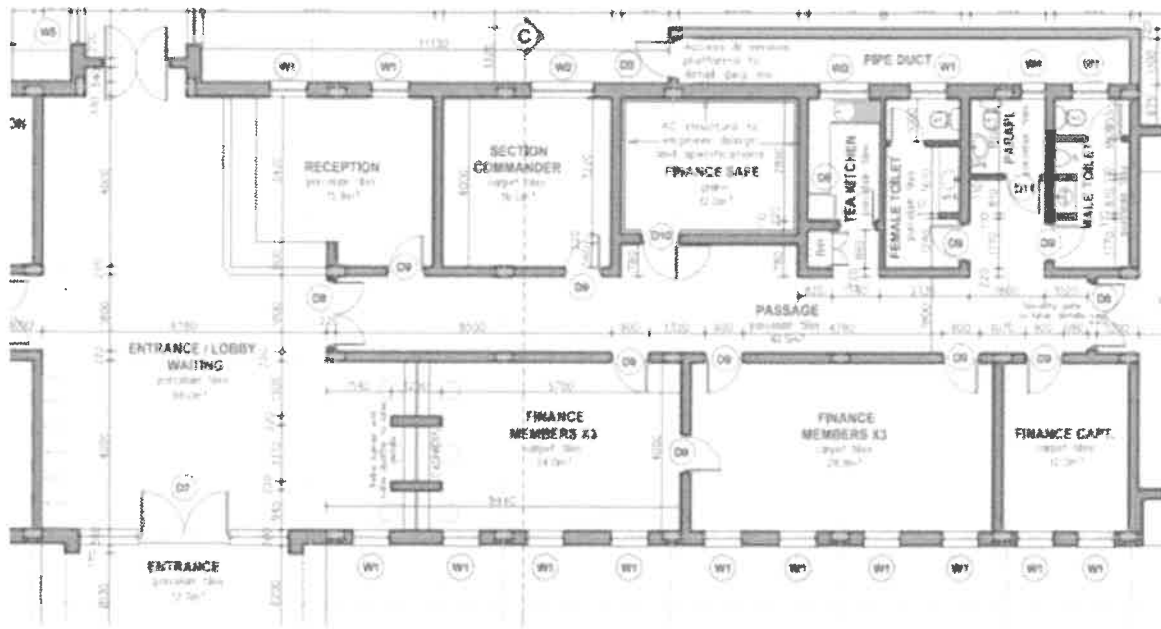

Example showing relation between public areas and semi-private areas

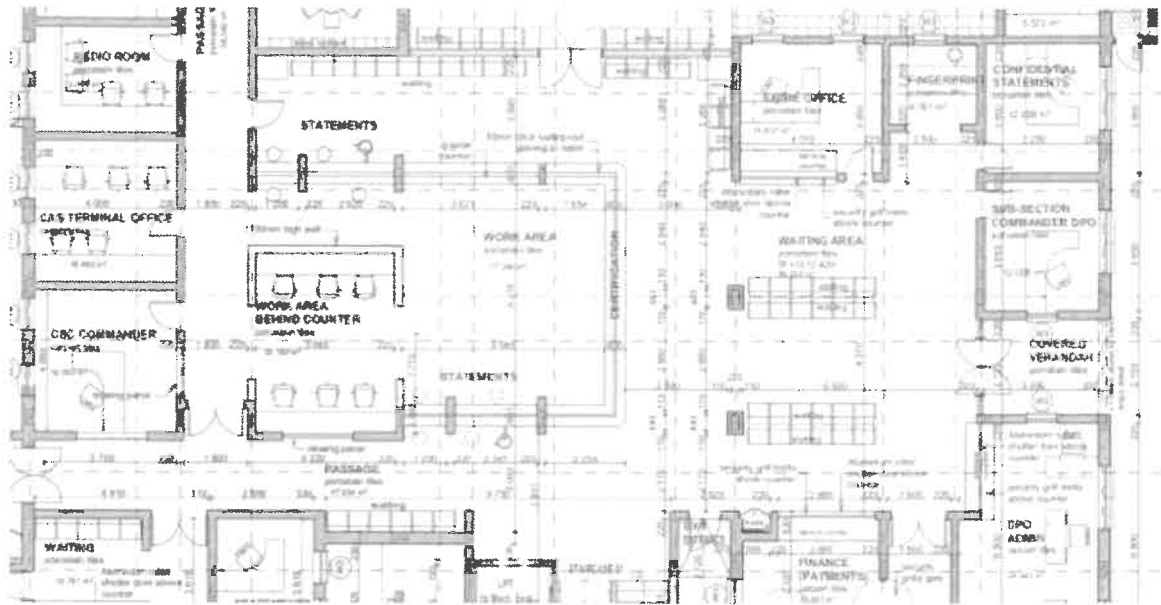

Example showing relationship between public areas

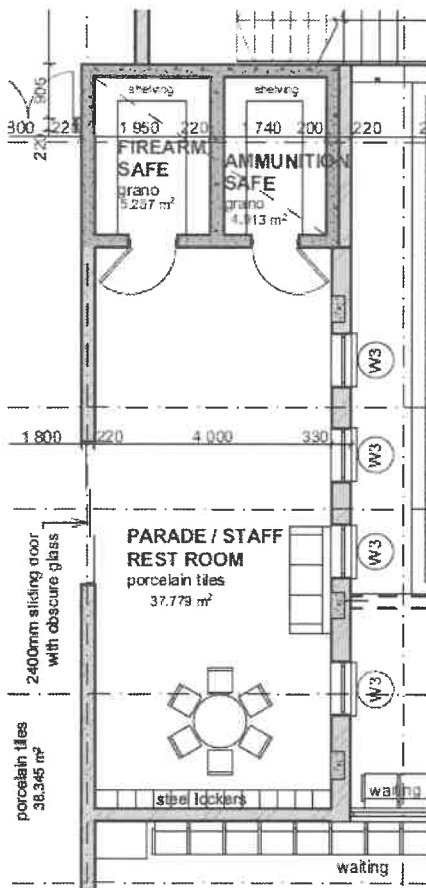

Parade Room

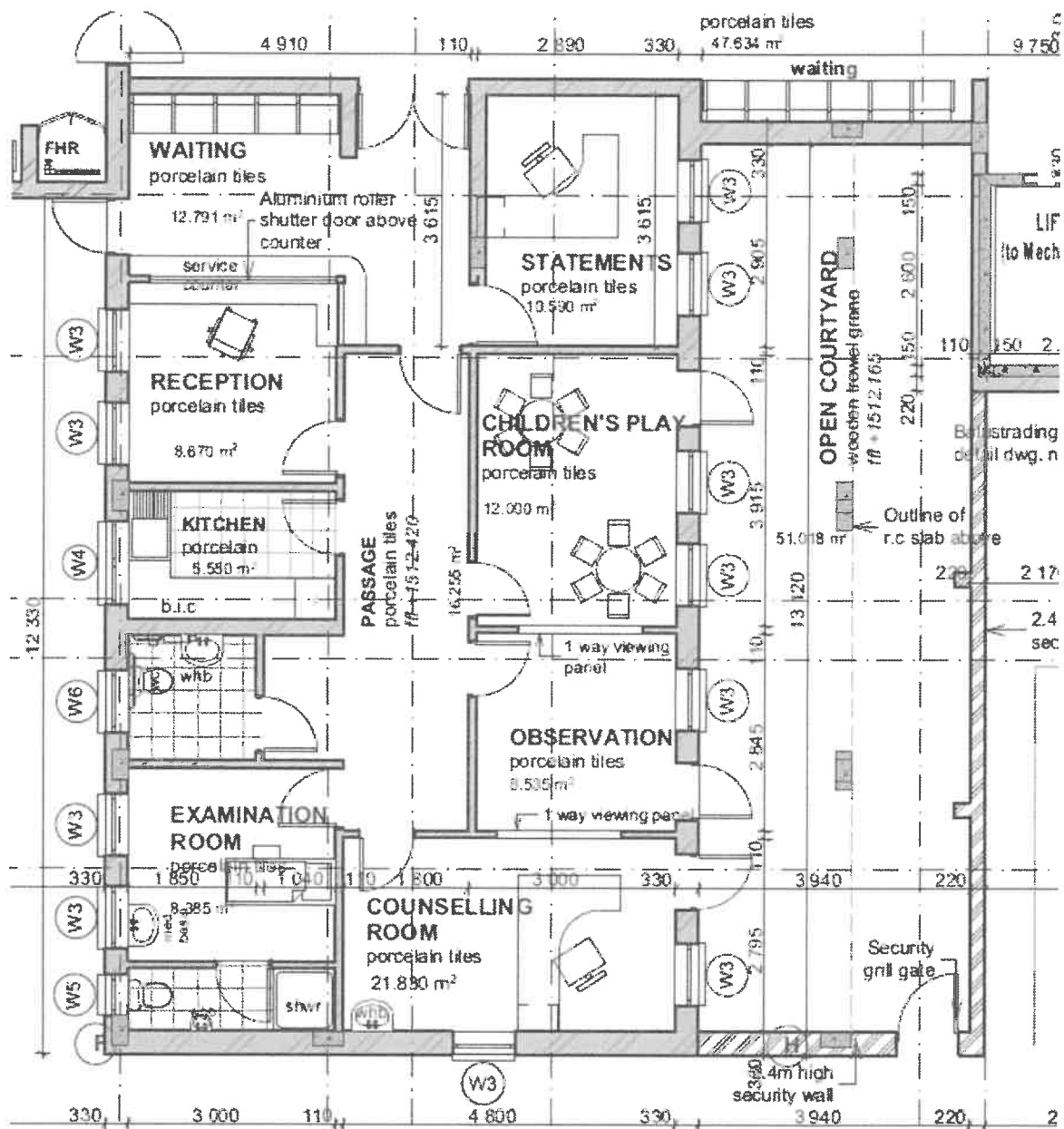

Example of Victim Support Unit

Example of a Procurement Instruction as provided by the Client and interpreted by NDPW&I.

DESCRIPTION OF ROOM	NUMBER FTE'S	SPATIAL RE- QUIREMENTS	ASSIGNABLE SQUARE METER
DIVISIONAL COMMISSIONER			
STATION COMMANDER	1	20	20
SECRETARY WITH WAITING AREA	1	16	16
VICTIM SUPPORT SERVICES			
COUNCELLING ROOM	1	12	12
TREATMENT ROOM	1	10	10
DETECTIVE SERVICES			
SECTION COMMANDERS	1	12	12
SUB SECTION COMMANDERS	1	12	12
MEMBERS LEV 7	3	8	24
MEMBERS LEV 6	6	8	48
ADMIN	1	10	10
DATA TYPIST	1	10	10
VISIBLE POLICING			
SECTION COMMANDERS	1	12	12
SUB SECTION COMMANDERS	6	12	72
SUPPORT MEMBERS	2	8	16
DATA TYPIST	1	10	10
CRIME PREVENTION: MEMBERS	26	2	52
FLASH: MEMBERS	2	8	16
FLASH: ADMIN	1	10	10
CIO: MEMBERS	2	8	16
SUPPORT SERVICES			
SECTION COMMANDER	1	12	12
FINANCIAL SERVICES			
MEMBERS	1	10	10
HUMAN RESOURCE MANAGEMENT			
MEMBERS	1	10	10
SUPPLY CHAIN MANAGEMENT			
MEMBERS	1	10	10
MANAGEMENT INFORMATION CENTRE			
MEMBERS	2	8	16
COMMUNICATION SERVICES			
MEMBERS	1	10	10
ADMIN			
MEMBERS	5	8	40
SERVICE POINT			
CSC COMMANDER	1	12	12
WORK AREA IN FRONT OF COUNTER	1	40	40
WORK AREA BEHIND COUNTER	1	20	20
PARADE ROOM	1	16	16
RADIO ROOM	1	17	17
CAS TERMINAL OFFICE	1	12	12
CRIME OFFICE	1	16	16
CELLS			
MALES	1	40	40
FEMALES & JUVENILES	3	18	54
STORES			
SAP13 STORE CLERK	1	12	12

APPOINTMENT OF PROFESSIONAL SERVICE PROVIDERS TO DEVELOP A DESIGN GUIDELINE FOR THE PLANNING OF BUILDINGS FOR THE SOUTH AFRICAN POLICE SERVICES

SUPPORT SPACE PER WORKSPACE AREA			
SERVICE POINT			
COVERED VERANDAH	1	15	15
TAKING DOWN STATEMENTS	3	1	3
TAKING DOWN SENSITIVE STATEMENTS	1	12	12
SHIFT WORKERS REST ROOM	1	24	24
KITCHEN/ LOUNGE	1	4	4
STATIONARY STORE	36	0.17	6
FINGERPRINT AREA	1	4.00	4
TEMPORARY SAP13 STORE	1	6	6
VICTIM SUPPORT FACILITIES			
RECEPTION AND WAITING ROOM	1	16	16
BATHROOM	1	4	4
DETECTIVE SERVICES			
CHILDREN PLAY ROOM	1	12	12
OBSERVATION ROOM	1	10	10
WAITING ROOM	1	16	16
VISIBLE POLICING			
WAITING AREA	1	16	16
JOC/WAR ROOM	1	40	40
GENERAL			
LECTURE/ TEA ROOM	30	1.40	42
LECTURE/ TEA ROOM	20	1.20	24
LECTURE/ TEA ROOM	25	1.10	28
REGISTRY	1	30	30
KITCHEN	1	4	4
COMPUTER/SERVER ROOM	1	9	9
WASH BAY AND WASH STORE	1	50	50
REFUGE AREA	1	24	24
EMERGENCY GENERATOR	1	12	12
STORES			
SAP13 STORE- SMALL ITEMS	1	18.00	18
SAP13 STORE- LARGE ITEMS	1	36.00	36
SAP13 STORE-LIQUER	1	36.00	36
GARDEN STORE	1	10.00	10
CLEANING EQUIPMENT	96	0.17	16
STATIONARY STORE	1	18.00	18
SAFE FOR STATION FIRE ARMS	42	0.17	7
SAFE FOR STATION AMMUNITION	36	0.17	6
SAP 13 FIRE ARM SAFE	1	10.00	10
SAP13 AMMUNITION SAFE	1	6.00	6
ARCHIVE	1	36	36
TYRE STORE	1	36	36
ROADBLOCK EQUIPMENT	1	18	18
DOCKET STORE	1	36	36
CELLS			
CELL COURT YARD	1	20.00	20
CELL COURT YARD	3	12.00	36
SECURED PASSAGE TO CELLS	1	13.00	13
SECURED PASSAGE TO CELLS	1	18.00	18
SECURITY SERVICE DUCT	1	5.00	5
SECURITY SERVICE DUCT	1	9.00	9
BLANKET STORE	84	0.17	14
PANTRY	48	0.17	8
KITCHEN	1	20.00	20
COURT YARD (KITCHEN)	1	16.00	16
PRISONER PROPERTY STORE	48	0.17	8
WAITING LOBBY	1	6.00	6
DECLARATION OF STATEMENTS	1	8.00	8
ADMITTANCE AREA	1	25.00	25
VISITOR ROOM	1	18.00	18
SEARCH ROOM	1	2.00	2
GEYSER ROOM	1	8.00	8
HOLDING CELL	1	10.00	10
ID PHOTO ROOM	1	10.00	10

APPOINTMENT OF PROFESSIONAL SERVICE PROVIDERS TO DEVELOP A DESIGN GUIDELINE FOR THE PLANNING OF BUILDINGS FOR THE SOUTH AFRICAN POLICE SERVICES

PARKING SPACE			
PARKING SPACE	-	28	-
OPEN PARKING	1	18	18
HEAVY VEHICLE PARKING SPACE	-	45	-
UNDERCOVER/ GARAGE PARKING FACILITY	24	28	672
SECURE DROP OFF AREA	1	50	50
SAP 13 VEHICLE CAMP	-	28	-

Each facility will have different requirements.

3.7 SCHEMATIC DIAGRAMS OF FUNCTIONAL REQUIREMENTS

Schematic layouts will explain the relationship between the various area and security zones, accused, staff, etc.

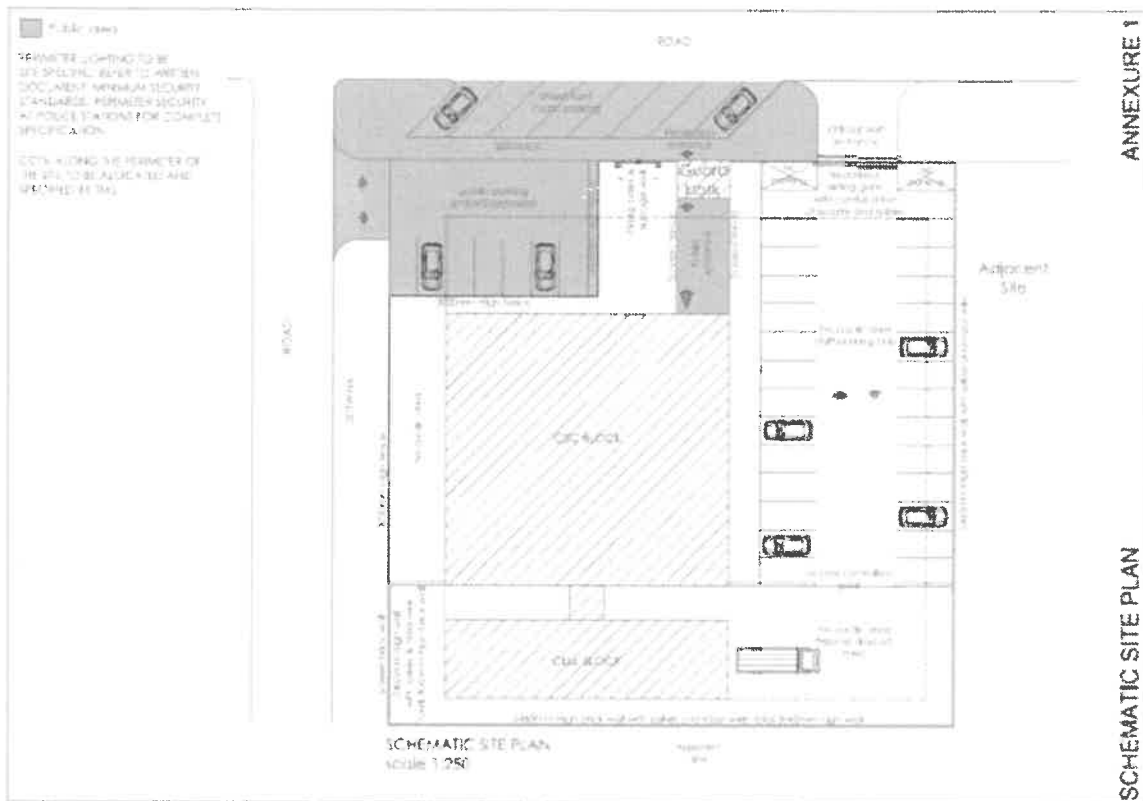

Schematic Site Layout: South African Police Services- Expert Services

Multi levelled facilities as well as single storey facilities will be expanded on. Similar schematic drawings are to be provided for the SAPS building as what is indicated below for Court Buildings in the USA.

Different security zones, circulation etc. will be explained through this process.

Typical Stacking Diagram

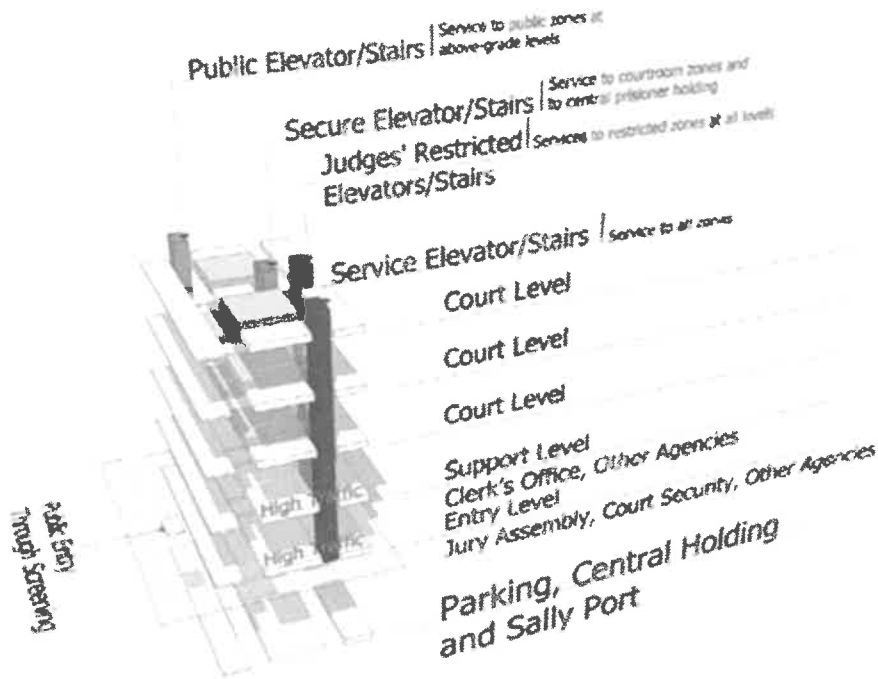

Organizational Relationships

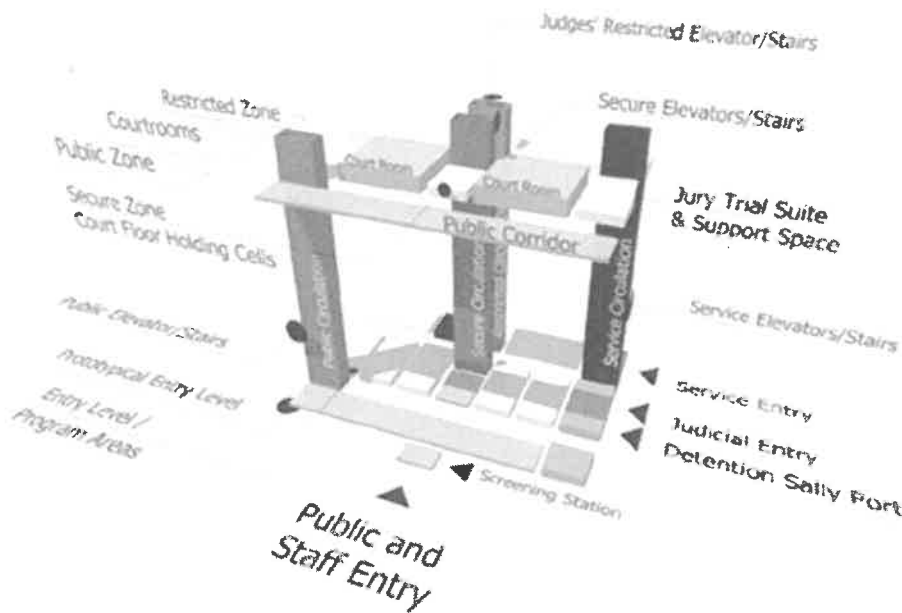

3.8 SPATIAL NORMS

Bubble diagrams must indicate the relationship between the areas and the diagrams must also provide the access routes relevant to staff, public etc. in relationship to the space positions.

The following spatial relationships, amongst others are to be developed:

3.8.1 A spatial relationship diagram to be developed for each type of Police Stations taking the types of security levels into account.

3.8.2 Organizational relationship diagram to be developed for each type of Police Station relating to its support spaces and users.

3.8.3 A process diagram to be developed for ways in which a police station functions including other participant interface with the police station e.g.

Department of Correctional Services, Defense and Prosecuting attorneys, Social Services, Cashiers, Public, etc.

3.9 SUPPORT AND ADMINISTRATIVE SPACES

This chapter addresses the administrative and support functions of the police station e.g. General offices for various units; archives, tea rooms, kitchenettes; witness waiting areas; etc.

Bubble diagrams and typical layouts as described above in item 3.8 will be provided for each together with relevant comments that apply to the function.

3.10 LANDSCAPE APPROACH FOR THE SITE

The landscape approach for different sites must be discussed and applied to site specific designs.

Landscape design must be completed by a qualified landscape architect.

The following aspects must be considered and must be included in the guideline, but **is not exhaustive**:

- 10.1 Plant material design and plant species application in public urban space
- 10.2 Bulk infrastructure considerations in site selection and development planning
- 10.3 Precinct and facility site management guidelines (with reference to maintenance guidelines once the site is handed over to the user) A checklist to ensure that all aspects have been covered is requested
- 10.4 Regional principles to suit the local context
- 10.5 Community participation and process guideline
- 10.6 Irrigation solution
- 10.7 Maintenance period, requirements and conditions.

3.11 BRANDING AND IDENTITY

3.11.1 Branding

The SAPS has their own corporate identity.

The corporate identity document will not be copied into the design guideline, but will be referenced. A copy will however be provided to the Project Manager as an attachment to the final submission of the guideline documentation.

The service provider will be tasked with obtaining all the relevant reference/ policy requirements that could have an impact on the design and to refer thereto and provide copies thereof tot the Project Manager.

Further branding/ identity specification exists for the following areas and must also be referenced and attached as an annexure:

- 1. Victim Support Unit
- 2. General Signage
- 3. Etc.

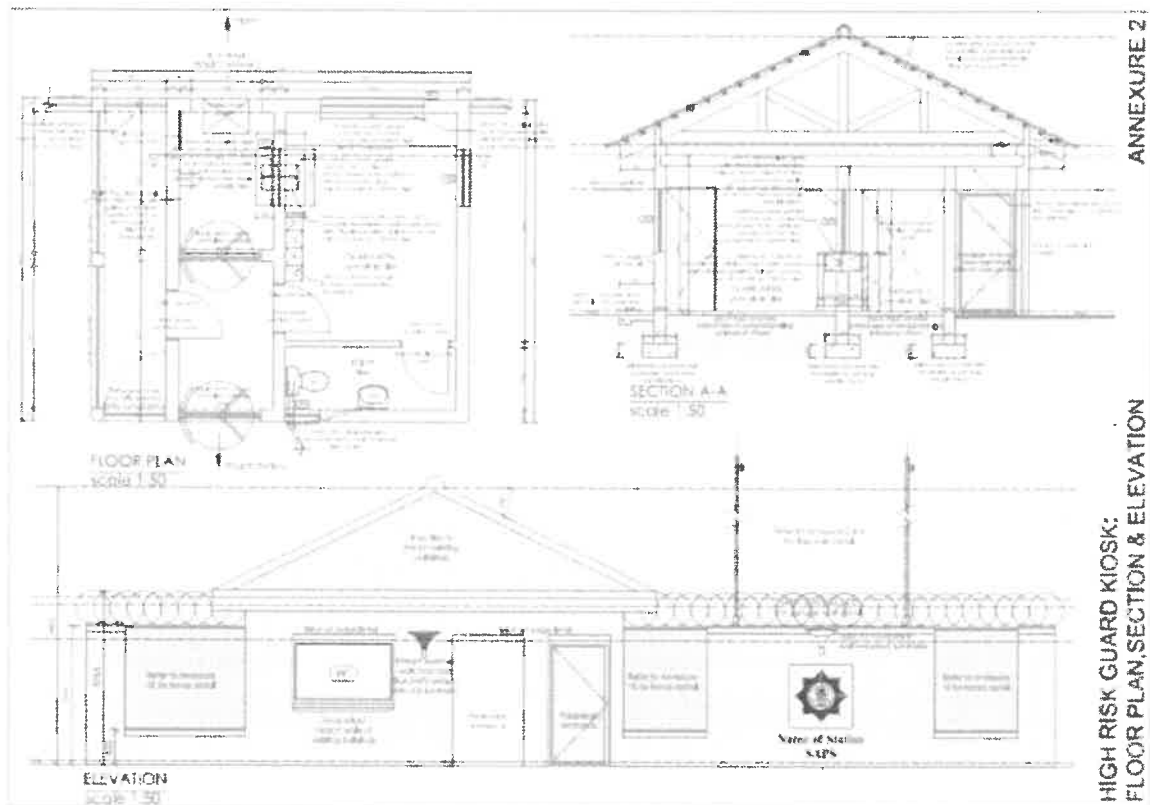

High Risk Guard Kiosk: South African Police Services- Expert Services

3.11.2 Identity

Each Police Station building will have its own identity due to the following initiatives/opportunities:

3.11.2.1 The provision of **landscaping** that is typical to a specific area, climate, slope, site conditions etc.

When considering landscaping to a building site the following aspects must also receive consideration- Types of plants (local indigenous, water), Irrigation systems, Maintenance.

Also refer to the NDPWI Sketch Plan Manual for further guidelines on Landscaping design and item 12. Landscaping Approach for the site.

3.12 FITTINGS AND FINISHES

The approach to the positioning of services must be determined to ensure that security is not compromised and the most cost effective layout can be achieved.

Diagrams such as the one below will indicate the floor to ceiling heights, void height, typical fittings and reference to the electrical and mechanical manuals. Although this diagram is that of a court facility, a similar approach is to be determined for police stations..

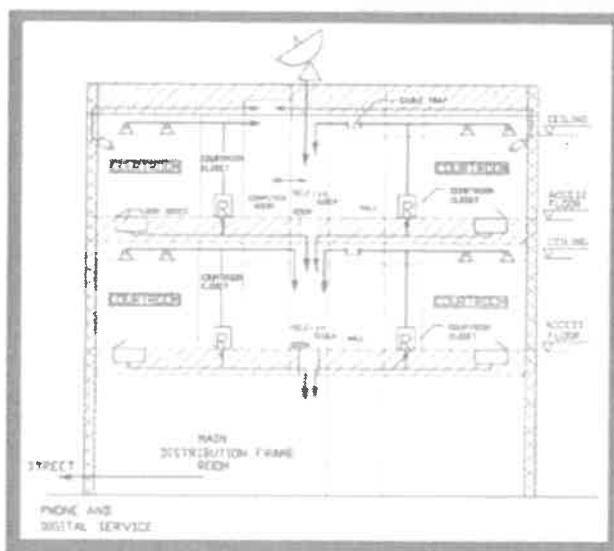

U.S. COURT - CABLE MANAGEMENT DIAGRAM

Reference: US Court Design Guide- Judicial Conference of the United States- 2007 Edition

Typical finishes will be described and a possibility of different choices will be given to ensure that there is some differentiation between the police stations.

A standard specification must be compiled.

Fixed furniture layouts, and details must be compiled. SAPS have various typical drawings that must be reconsidered and updated if need be. An example is pasted below.

APPOINTMENT OF PROFESSIONAL SERVICE PROVIDERS TO DEVELOP A DESIGN GUIDELINE FOR THE PLANNING OF BUILDINGS FOR THE SOUTH AFRICAN POLICE SERVICES

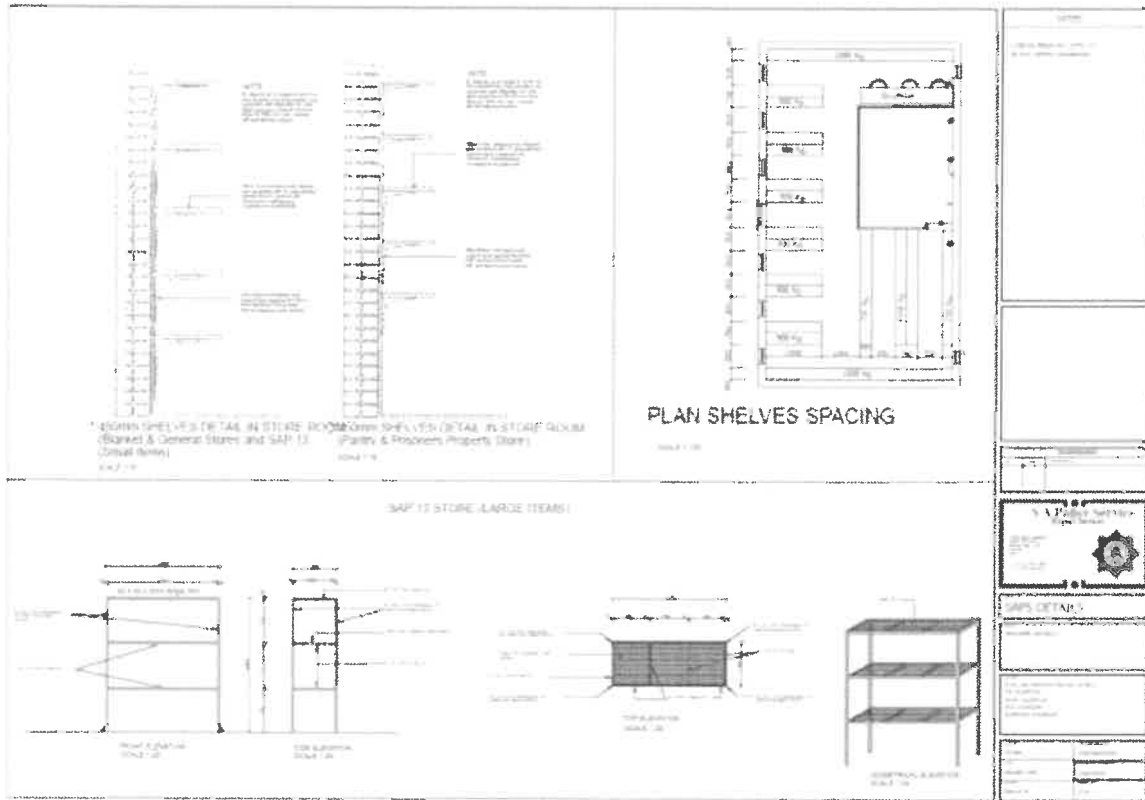

Existing Shelving detail to be reconsidered and updated if needed

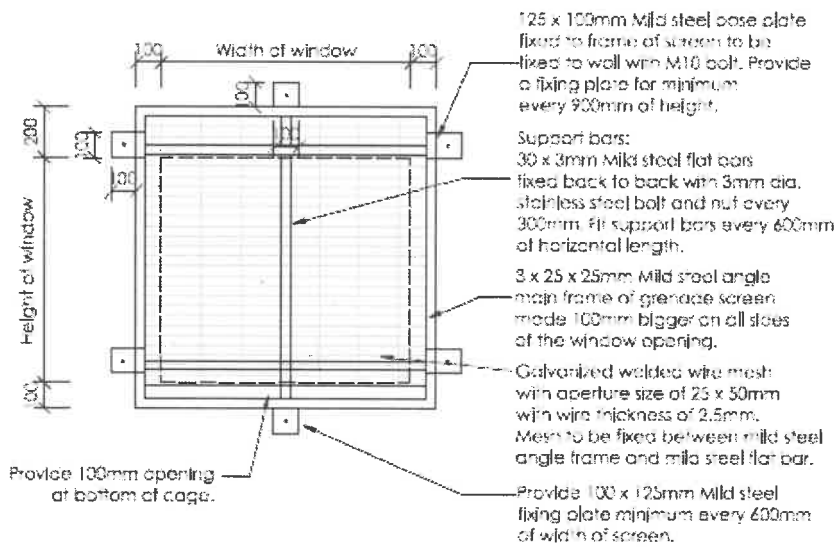

GRENATE SCREEN DETAIL
FRONT ELEVATION
 scale 1:20

Existing Grenade Screen detail to be reconsidered and updated if needed.

Reference is to be made to the PW 371-A and PW 371-B relating to the specification of materials, fittings etc.

Fittings, as indicated in the existing standard documentation is to be interrogated, verified as still valid, corrected, changed, added to, etc.

Typical fittings, as well as specific fittings to be listed per function/area.

For example: PUBLIC ENTRANCE FOYER:



- Lobby & Waiting Room: Seating/ Benches
- Visitors Search cubicle: Hat & Coat Hooks
- Female, Male, Paraplegic WC: Vitreous china type WC's & WHB's, soap dispenser, toilet roll holders, hand dryers, mirrors
- Security Counter: Counter, etc.
- Passage: Fire Hose Reels, Fire Extinguishers

Typical finishes are to be developed for all the areas including alternatives in order to provide a possibility of different choices to ensure best economical and practical finish for a specific project, addressing local content and allow for some differentiation between police stations.

The outcome of the above could be reflected in a general list.

Example of Typical Architectural documentation available that must be updated should it be needed, etc.

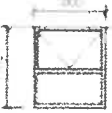
Typical approach to certain areas relating to roof and ceiling types should be developed. This would include elevations, sections and plans. Section indicating approach to roof types relating to security to be developed. i.e. Cell area including areas where inmates could access to have concrete roofs with plaster soffit ceilings, administration area can have other types of roof finish and particular ceiling types, etc.

CONSTRUCTION CALCULATION: AS PER SANS 10400 & 204 PART 1-2 ALLOWABLE ESTIMATION SHALL NOT EXCEED 1% OF TOTAL FLOOR AREA. NOTE: NE APPROX WITH 10% TOLERANCE IF A 2% TOLERANCE IS REQUIRED, THE MEASUREMENT SHALL BE TO THE CENTRE OF THE MEMBER. FOR CONCRETE TO BE MEASURED TO THE FACE OF THE MEMBER. FOR WALLS OF BRICKWORK, THE MEASUREMENT SHALL BE TO THE CENTRE.	WINDOW SCHEDULE				
		REFERENCE NO.	W1	W2	W3
	QUANTITY	1	1	1	1
	FRAME FINISH	Painted aluminium sliding frame	Painted aluminium sliding frame	Painted aluminium sliding frame	Painted aluminium sliding frame
	GLAZING	12mm thick double glass with safety interlayer	12mm thick safety glass	12mm thick double glass with safety interlayer	12mm thick safety glass
	PENETRATION AREA	2.16m ²	1.20m ²	1.68m ²	1.04m ²
	FLOOR/ LOCATION	Shop floor - window	Workshop with SAPS and police	Workshop	Shop

Window Schedule: South African Police Services- Expert Services

3.13 SIGNAGE

Signage in compliance with SANS and Universal design with reference to way finding systems.

Adaptability to be determined- i.e. when including the name of a person- who can leave the staff establishment of the police station or should only the post title be provided?

Due to difficulty in obtaining the correct language translation, a standard list is to be developed and included in this document that contains all official languages. This list can then be utilized without requests for information from the client department for every project developed. The policy of SAPS is to be obtained and implemented.

Standard sizes; systems to be determined.

3.14 ACOUSTIC TREATMENT

The acoustic treatment of the public areas important due to the sensitivity of statements being taken. The following aspects must receive attention and specifications are to be provided for each.

1. Material choices for floors, ceiling and walls
2. Ceiling height, material, etc.
3. Mechanical equipment choice
4. Mechanical equipment placement
5. Etc.

3.15 BUILDING MANAGEMENT AND SECURITY

1. Type of building management system provided
2. Monitoring of electricity and water use is a requirement
3. Support available in malfunctioning of system
4. Ease of fixing materials/ systems, etc.
5. Policy regarding stockpiling of material/ equipment
6. Training of staff and Maintenance staff
7. The different kinds of security zones/ perimeters are to be defined and described.

For some examples, see diagram and information below.

Define and describe safety zones

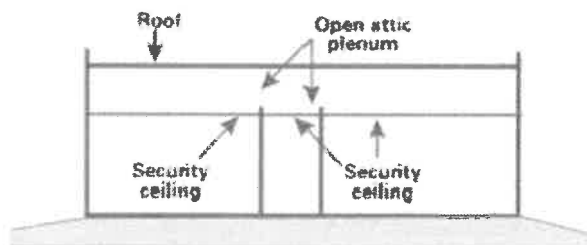

The following information is applicable in the Food Services/ Kitchenettes:

Floor: concrete slab

Walls: 230mm Thick brick wall- plastered and painted

Ceiling: Security mesh below plasterboard ceiling/ painted soffit of reinforced concrete slab

Ceiling height: 4.565m (min. height e.g. for smaller kitchens/ exist.)

Windows: Cell type windows.

Doors: Specialised steel door in accordance to SAPS 5 Star requirement with lock provided by SAPS.

The different functions/ rooms within an area to be taken into account.

Other security measures to be defined and described per site and per function.

Furthermore the following must be addressed:

1. Access control types i.e. biometric/ card etc. (from an architectural perspective)
2. Camera positions, types, conduit type and position etc. (from an architectural perspective)
3. Security glass in visiting booths etc.
4. Security risks must be defined and described per site and per function

For example:

Signage (type, fixing, fixing height etc.)

Light fittings e.g. type, fixing, grills over light fittings/cameras

Cover plates –electrical and otherwise

Access to equipment e.g. fire prevention equipment

Other e.g. ceramic toilets in a secure area; position of inmate drop-off area etc.

5. Access routes
6. Cell area (signage, cameras, fittings, ceiling types, services etc.)
7. Ceiling, window, glass and wall types for different areas

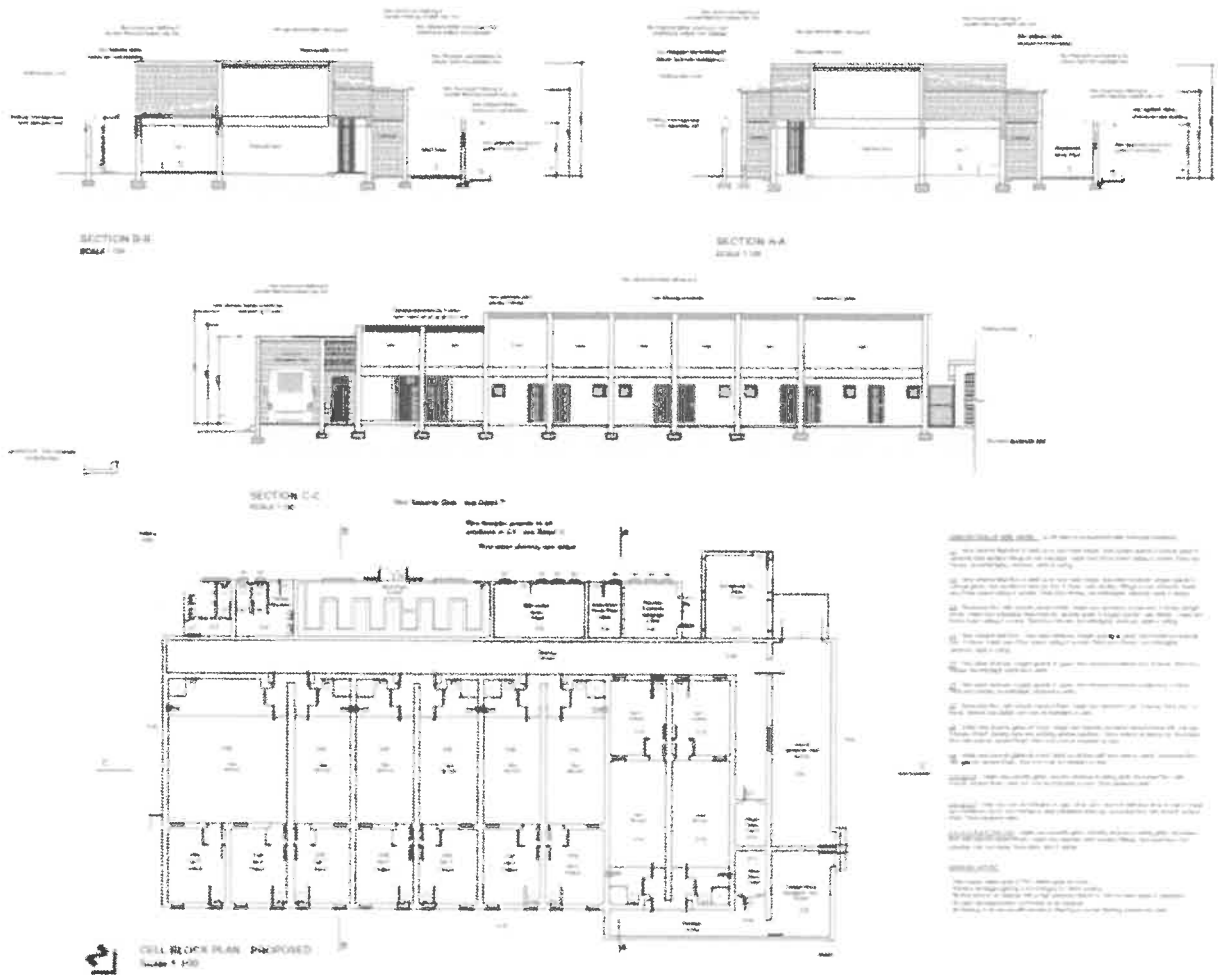

Cell Block: South African Police Service: Expert Services

3.16 MAINTENANCE MANAGEMENT

1. Access to services for maintenance (lights, air-conditioning etc.)
2. Window washing and cleaning- accessibility and safety
3. Pigeon proofing
4. Type of building management system provided (Can the system assist with monitoring, reporting and identification of electricity and water use/ leaks etc. Also refer to 17 above)
5. Policy regarding a Maintenance manual
6. Guarantees, warranties, and who keeps it and ensures that maintenance is followed up timeously

APPOINTMENT OF PROFESSIONAL SERVICE PROVIDERS TO DEVELOP A DESIGN GUIDELINE FOR THE PLANNING OF BUILDINGS FOR THE SOUTH AFRICAN POLICE SERVICES

3.17 SUSTAINABILITY AND “GREEN” DESIGN

The design guidelines should aim to improve sustainability and address environmental aspects in planning, design and management and should seek to implement green design principles. Sustainability/ “green” buildings are seen to include energy, water and waste management and infrastructure. The aspects below are examples of the areas that must be covered and must be expanded upon.

3.17.1 The following aspects must be elaborated on and the list expanded to cover energy, water and waste resources:

- The building should be **functional, accessible, cost-effective to maintain, resilient and sustainable** in terms of waste and energy.
- Compliance with **SANS 10400 XA** is a requirement.
- The consultant team must include at least one **accredited professional** as validated by the GBCSA.
- **Passive design principles** must be applied (orientation, limitation of windows on the eastern and western facades, overhangs, sun screening etc. all appropriate to the relevant climatic zone).

Building orientation has an economic impact. How much direct energy use does interior lighting normally have for a site, including induced HVAC use due to heat produced by them?

Creating a day-lit interior saves capex and opex. Appropriate building envelope design in response to orientation, end-user needs and environmental context allows for the introduction of passive design innovations such as sun shading, thermal mass storage and potentially even natural ventilation based on prevailing wind conditions further reducing the HVAC load.

- Longer narrow shape naturally allows natural lighting and ventilation; and bringing stairs, mechanical systems like lifts and restrooms to the building's core creates a flexible and open surrounding floor plan. Making sure users can adjust windows and skylights will enable natural ventilation on good weather days.
- When interventions are proposed, a **life cycle costing** must be presented to ensure that the payback period is acceptable. Analyse what the difference in cost will be on each part of the building project before a funding decision is made. Guide/ check list to be included to ensure that this can be done uniformly for all projects.
- **Landscaping** adds value in that direct sunlight baking into the dark non-reflective surfaces surrounding your building will create a heat island, as will north and west-facing building walls. Lattice for climbing plants creating a green screen will reduce this effect, as will the shade from mature trees over walls, roofs and parking areas. Living, green roofs are also proven to reduce the heat island effect, assist with storm water attenuation and contribute towards the comfort index of those inside the building too. Also refer to item 12 relating to the Landscape Approach for the site. Proposals are to be aligned with security requirements.
- **Water harvesting, storm water management, utilization of grey water, reticulating stormwater run-off and re-use** thereof must be considered and a recommendation made to the department. Guide/ check list to be included to ensure that this can be done uniformly for all projects.
- **Water saving devices** e.g. Smaller WHB, Push taps, motion sensors, vapour- only tap fittings back, low-flow toilets, indigenous and water-wise gardening. etc.

- **Electricity saving devices** e.g. Motion sensors, light fittings, etc. Motion sensors on restroom taps, and office lighting with automatic dimmers.
- **Alternative energy resource** that is relevant to the climatic zone is to be proposed as aligned to SANS 10400 XA.
- It may from time to time be requested that a building must be rated with the GBCSA but this is not a requirement and must specifically be stated in the appointment letter.
- **Integrated design approach** addressing the site, both the exterior and interior plans as well as the budget to give their necessary input on the effect that each planning decision will have on the overall project as well as the sustainability impact of the various design choices. Guide/ check list to be included to ensure that this can be done uniformly for all projects.
- Avoid contributing to sprawl.
- All proposals are to be made while keeping maintenance of the building in mind.
- Maximum use should be made of solar light to effect acceptable light levels throughout the building during daylight hours.
- Maximum use should be made of solar radiation to provide the heat in the building required for comfort and the hot water which is associated with the functioning of the building. Note that the supply of hot water in the bathroom / toilets in normal office buildings is not a requisite. The need for such provision must be properly motivated for and substantiated. Appropriate approvals must accompany the applications.

- Additional heating and cooling, if required either for health purposes, in the case of comfort space heating, or for direct functional purposes in the case of air-conditioning or cooling being required may only be considered as an option if all renewable options or passive solutions (selection of construction materials, provision of shading, roof overhang, reflective glass or film over glass, window sizes, sill height above floor level, insulation, air movement etc) have been implemented / exhausted. The capacity of heating or cooling must only provide for the calculated deficit.
- The requirements of SANS XA must be followed / satisfied.
- All lighting in the building and on the site must be of the highest feasible energy efficiency rating, controlled by day / night switches, and in office areas they must only function when offices are occupied.
- The following energy conservation measures in respect of hot water generation must be applied:
 - (i) Should electrical power be intended for use in generating substantial volumes of hot water for specific functional areas and purposes, heating must be done by a heat pump system. The suitability of incorporating solar heating in this system should be investigated and reported on.
 - (ii) The provision of hot water should be limited to applications where it is required by way of specific operational requirements.
 - (iii) The temperature of the hot water entering into the supply lines must be set as low as is reasonably practical, but also make provision for the fact that the eradication of Legionnaires disease (*Legionella Pneumophilla*) requires a water temperature of 60°C to be reached and maintained for

a reasonable time, while the maximum temperature at the showers outlets / faucets may not exceed 45 °C, especially where patients and prison / police cell inmates are accommodated.

- (iv) Hot water pipes must be lagged, also where they are embedded in the walls.
 - (v) The use of resistive heated hot water systems should be avoided. Hot water should only be supplied for special purposes. The number and capacity of hot water installations are to be kept to a minimum.
- Should the use of resistive heated hot water systems be unavoidable, this should be motivated and the units are to be well insulated internally, the insulation being of such quality and thickness so as to obviate the need for further thermal insulation such as achieved with “geyser blankets”. The length of hot water of pipes should be minimised. Where possible, hot water cylinders should be piggy backed by solar water heaters.

3.18 CHECK LISTS

Various Check Lists are to be developed to ensure that alternatives can be evaluated appropriately and uniformly for all designs. An example of such a checklist is mentioned below with a guide of the aspects that should be covered in the list.

Example of information required for a checklist to be developed to motivate the installation of e.g. **Photovoltaic panels**.

Indicate the financial viability and payback in 3-5 years of the system.

The financial viability of solar PV is dependent on a number of different factors:

- Installation size: larger projects produce cheaper electricity as fixed costs, such as design and specification, are spread over more panels.

- Technology choice and exchange rate: prices still vary and some components need to be imported.
- Location, roof type and direction: influence the amount of sun reaching the solar panels.
- Consumption patterns: Eskom charges a peak charge during periods of highest use (typically, in a business context, during the day). Generating one's own electricity (also most effective during sunny periods) results in greater savings. Identify the base load, loads the will use PV and supplement Eskom power.
- Maintenance of PV System: Type of maintenance, frequency and replacement cost. Total ownership cost
- Life span of PV system / replacement period and cost: Design life of PV system, Life expectancy of PV Panel, Batteries, AC/DC Converters, Surge protection.
- All hot water systems to be solar backup with electrical supply. Heat pumps to be considered instead of solar as a more energy efficient solution.
- When PV panels are installed the roof footprint shall be sufficient for a cost effective PV installation.
- Thermal heating and cooling via Solar systems to be considers as part of the 20 % renewable energy efficient systems.
- Eskom by-laws on feeding back in to their system must strictly be followed to ensure a safe alternative supply to each building and future revenue by selling power back into the grid.
- All PV systems to be metered with Quality of supply meters to verify KWH, KWp generated into the system from the PV System. (Metering of normal power and PV power system separately)
- Type of system – Grid system or grid tied system.

3.19 CONTEXTUAL RESPONSE

The following examples of design principles must be adhered to and must be elaborated on in the design guideline (Additional items to be added):

- **Site considerations** such as orientation, slope, ground conditions, positioning of wetlands/ existing trees, climatic zone, relevant heritage implications, position of site from other relevant entities, etc.
- Spaces to be sized to ensure most efficient **structural spans** to be used.
- **Heavy live load** areas such as archives, storage, etc. are to be placed on ground level to ensure compliance to loads whilst being economical.
- Windows and glazed areas within the building should comply with **SANS requirements** relating to energy efficiency as well as security requirements due to the function within and could therefore become costly if not kept to the effective minimum e.g. cash hall windows are to be bullet proof internally and external windows are to be screened/ bullet proof/ not accessible or visible.
- **Building shape** is to be most economical whilst taking the site into consideration. Odd spaces created because the areas are not square should not be encouraged.
- **Natural light and ventilation** should receive priority.
- **Positioning of services, lights** etc. that requires **maintenance** must be accessible and the building shape should take the cost of such infrastructure due to the shape of the building into account. Conduit/ pipe etc. lengths will have an impact.
- Building design must include **Universal Design** principles in all aspects.

- **Optimal building depth** is to be allowed to ensure that there are no internal offices or spaces. Should there be no other option, spaces such as service areas, libraries, archives, storage etc. should be located internally.
- **Co-ordination between various disciplines** must be done and best site specific proposal is to be provided.
- All South African Acts, NBR, SANS 10400 regulations are to be complied with.

3.20 APPROACH TO TECHNOLOGY

- An approach to the provision of infrastructure to accommodate smart technology must be provided. This will include provision of conduiting etc. to allow for electronic equipment to be connected, without later chasing etc. into the infrastructure.
- An approach to retrofitting should also be developed for implementation during an addition.
- Research must be conducted to determine the facilities, infrastructure and equipment that must be provided to ensure smart SAPS buildings. This will inform a revised Procurement Instruction and guideline. The service provider must provide a recommendation in this regard.
- The provision of a security system as managed by a specialist professional in the field must also be considered in this phase to ensure that the infrastructure requirements for this equipment is sufficient.
- Other facilities that are included in this item will be telephonics, network points, building management systems. Other installations may be identified during the research process identified in item 21.3.

3.21 GLOSSARY

The Service Provider must complete the Glossary by expanding on acronyms, definition, etc.

Example:

NDPWI	National Department of Public Works and Infrastructure
FM	Facilities Management
IT	Information Technology
PEP	Project Execution Plan

The following is another example:

4IR	Fourth Industrial Revolution	ACFTA	African Continent Free Trade Area
ABIS	Automated Ballistic Identification System	AFIS	Automated Fingerprint Identification System
AGSA	Auditor-General of South Africa	AOP	Annual Operational Plan
APP	Annual Performance Plan	AR	Annual Report
AU	African Union	BMA	Border Management Agency
CCTV	Closed Circuit Television	CIPA	Critical Infrastructure Protection Act
CJS	Criminal Justice System	CPA	Criminal Procedure Act
CPF	Community Police Forum	CRIM	Criminal Record Information Management (System)
CSF	Community Safety Forums	CSPS	Civilian Secretariat for Police Services
CSPs	Community Safety Plans	DVI	Disaster Victim Identification
DoCGTA	Department of Cooperative Governance and Traditional Affairs	DoJCD	Department of Justice and Constitutional Development
DPCI	Directorate for Priority Crime Investigation	DPW	Department of Public Works
DPSA	Department of Public Service and Administration	DPME	Department of Planning, Monitoring and Evaluation
EFRS	Enhanced Firearms Register System	EMCS	Enhanced Movement Control System
ECM	Enterprise Content Management	FSL	Forensic Service Laboratory
FTD	Field Terminal Devices	GBVF	Gender-based Violence and Femicide
GDP	Gross Domestic Product	GPSJS	Governance Public Safety and Justice Survey
ICDMS	Investigation Case Ticket Management System	IPM	Integration Persons Management
IS/ICT	Information Systems/Information and Communication technology	JCPS	Justice Crime Prevention and Security
LIMS	Laboratory Information Management System	MCS	Movement Control System
NISS	Minimum Information Security Standards	M&E	Monitoring and Evaluation
MOSAC	Modul Operandi Strategic Analysis Centre	MTEF	Medium term Expenditure Framework

South African Police Service | Annual Performance Plan 2020/2021

3.22 LIST OF ANNEXURES

All annexures to be listed as well as where the document can be obtained.

Policies can be changed and to ensure that the consultant architect always utilizes the latest, correct document it is suggested that the reference rather be given in the design guide. For submission purposes however the service provider is requested to provide all relevant documentation to the Project Manager separately.

Example:

Annexure A -

Annexure B -

Annexure C -

Annexure D - SAPS Specification for Mothers and Babies

Annexure E - SAPS Specification for Victim Support Areas

Annexure F - SAPS Signage Specification

Annexure G - SAPS Policy on Corporate Image

Annexure H - SAPS 5 Star Cell Specification

3.23 REFERENCES

All references utilized during the compilation of the design guideline is to be listed

DPWI documentation that should be considered for this guideline and that could be of reference amongst others:

DPW Manual for Private Architects: PW147

DPW Sketch Plan Committee Manual: October 2016

The above and other is available on:
<http://www.publicworks.gov.za/consultantsdocs.html>

Other documents include:

Empowerment Policy (NDPWI - 2016)

IKS (Indigenous Knowledge Systems) [NDPWI – 2016]

4. DELIVERABLES

4.1 The **Design Guideline** shall include:

- Integrated planning **guidelines** for the development of sustainable police stations
- **Operational and spatial models** to support the user departments' requirements for police station
- **Standard materials** that can be utilised provided that that material is the most appropriate for the specific site relating to availability, cost, sustainability etc.
- **Standard Block Designs** that prescribes the furniture, layout, fittings, etc. of a specific area
- **Updating of existing plans/ details/ elevations etc.** to incorporate new policies and technology advancements
- **NDPWI Priorities** e.g. EPWP, sustainable design, water efficient design, etc.
- Reference to **supporting documents** as described elsewhere in this document
- The particular grouping of spaces will be determined by the **Procurement Instruction** as issued by the Client Department through the NDPWI
- **Checklists** that will guide the consultants to deliver uniformly on various aspects as described above.

4.2 Deliverables

A guideline is required to assist the future delivery of the planning programme that is aligned to existing Standard Operating Procedure specific to the South African Police Services. The guidelines should be able to address and inform a multi-disciplinary team to execute the project over the various phases.

Currently, the operational standard for design of new facilities for the South African Police Services vary considerably.

The following are **specific deliverables**:

- a) **Inception Report** and **Status Quo Report** (clarify the scope of works, data assembly and reporting on the current status) together with a Project Execution Plan (PEP)
- b) Identification of **Existing Policies and Guidelines** that could be applicable to police station planning
- c) Development of **Operational Spatial Models** for Police stations.
- d) Development of **Checklists** for the planning, design and management of Police stations
- e) Development clear set of **Generic Guidelines** for the planning, design and management of Police Stations
- f) Development of **Standard Material Choices, Standard Construction Details** and **Schedules** that could be utilised
- g) Development of **Typical Layouts** for specific areas that would be standard within the Police Station (e.g. counters, cash hall etc. Existing plans/ details etc. to be scrutinised and updated to newest policies
- h) Develop a **High Level Maintenance Strategy** for Police Stations and alignment possibilities with EPWP

- i) **Other** Items/ aspects that may be identified
- j) Development of checklists for the planning, design, and management of Police Stations/ facilities.

4.3 Submission of Planning Guideline

This deliverable provides for the handover of information and data in the following format:

- a) All draft documentation must be provided in soft copy (both MS Word and PDF) and hardcopy.
- b) DPWI Project Manager to be provided with four (4) hard copies of the final document in an A4 size. The documents must be ring bound, proper designed front page on card stock cover (minimum of 216 GSM), full colour and printed on matt paper with a minimum of 105 GSM, all to DPWI Project Manager's approval.
- c) The DPWI Project Manager to be provided with two (2) soft copies of the final document in MS Word (or in the format the final document was created in) and PDF, saved on separate USB flash drives.
- d) Interim payment for the different deliverables will be allowed on completion of a specific deliverable as identified in Critical Milestones.

5. CRITICAL MILESTONES

The project has to be delivered in a period of seven (7) months. During this time period, the following critical milestones must be achieved.

DELIVERABLE	DESCRIPTION	% PAYABLE	TIME FRAME
Inception Report, Status Quo Report & Existing policies and guidelines applicable to planning of a correctional centre	Inception Report to clarify the scope of works, data assembly aligned with the Project Execution Plan (PEP) Status Quo report to clarify the current status of documentation available and linking the applicability to the design guideline and align with the Project Execution Plan (PEP) Identification and report on existing policies and guidelines that could be applicable to this project.	9.64%	2 weeks
Operational spatial models, Generic Guidelines, Standard material choices and schedules & Typical layouts	Development of operational spatial models for different Prison Types (figures) . Development clear set of generic guidelines for the planning, design and management of Correctional Centres . Development of standard material choices and schedules that could be utilised. Development of typical layouts for specific areas that would be standard within the Correctional Centres . <u>The above deliverables should demonstrate how ALL items, identified in the Table of Contents, were addressed.</u>	53.5%	15 weeks

Maintenance Strategy	Develop a high level Maintenance Strategy for Correctional Centres and alignment possibilities with EPWP	10.20%	3 weeks
Checklists	Development of checklists for the planning, design and management of Correctional Centres.	12.16%	3 weeks
Final Document and other items	Submission of Planning Guideline for the development of Correctional Centres/ Facilities.	14.5%	5 weeks
TOTAL		100%	28 Weeks or 7 Months

6. SKILLS REQUIREMENTS

The following skills are the minimum that should be included in the project team.

Key Skills Set	Minimum Qualification
2x Professional Architects (includes Project Leader)	Bachelor degree in Architecture Registration with SACAP as Professional Architect (including SACAP Letter of Good Standing)
Professional Architectural Technologist	Registration with SACAP as Professional Architectural Technologist
Professional Landscape Architect	Bachelor degree in Landscape Architecture Registration with SACLAP as Professional Landscape Architect (including SACLAP Letter of Good Standing)
Professional Quantity Surveyor	Appropriate accredited degree, diploma or professional qualification Registration with ASAQS as Professional Quantity Surveyor (including ASAQS Letter of Good Standing)
Professional Sustainability Consultant	Appropriate bachelor degree in Built Environment
Graphic Designer	Appropriate bachelor degree in Graphic Design

7. FUNCTIONALITY CRITERIA

The following functionality criteria establish the minimum requirements that the project team must comply with.

Functionality Criteria	Weighting Factor
<p>Qualifications and experience of the Project leader</p> <p>The service provider for this project should indicate the allocated Project Leader's experience in work of a similar nature and scope. The Project Leader shall be in the full time employ of the service provider. The project leader must have a Post grad/Bachelor qualification in Architecture and a minimum of 15 years' experience in the respective field as well as professional registration with the relevant council.</p>	20
<p>Qualifications and experience of the Key specialists (Project team)</p> <p>The project team must have at least one (1) member that has a Bachelor qualification in Architecture and a minimum of 10 years' experience in the said field as well as professional registration with the relevant council.</p>	20
<p>Relevant experience in projects of similar scale and nature</p> <p>Proven experience of completed projects of similar scale and nature of the project as specified as follow:</p> <ol style="list-style-type: none"> 1) Development and assembly of existing policies, guidelines 2) Generic building design guidelines <p>Note: Where the entity tendering is a joint venture a score for track record will be awarded to each party to the joint venture, which will then be combined in proportion to the percentage contribution of each party to the joint venture.</p>	20

<p>Value Added</p> <p>Demonstration that the client will derive better value for money by contracting with the tenderer in providing the following:</p> <ol style="list-style-type: none"> 1. New and innovative knowledge in terms of International benchmarking; 2. Methodology to transfer knowledge to NDPWI team; 3. Use of BIM technology; 4. Demonstration of project appropriateness to public infrastructure; 5. Quality of proposal presentation. 	10
<p>Proposed programme plan</p> <p>Demonstrate the approach/ methodology to follow with this project by providing information on each of the following subheadings:</p> <ol style="list-style-type: none"> 1. Approach/ methodology for this project 2. Approach to quality control, 3. Approach to project management, and 4. Approach to team communication. 5. Quality of project comprehension demonstrated in proposal i.e. project execution plan, proposed timeframe for the project 	30
Total	100 Points

8. CONCLUSION

The above information is not intended to be a final and complete list of items to be included in the Guideline document, but aims to guide to Service Provider relating to the requirements in the document. This is proposed as a minimum requirement. Deviation from the proposed content list can be made to the Project Manager for consideration. All alterations/ proposals must be done in writing and must be accepted in writing by the Project Manager prior to execution. **Alteration to the list of items upon approval of the PM will NOT attract additional fees.**

Project Team	Rate per Hour (as per NDPWI Reimbursable Rate Table)
Project Leader	
Professional Architect	
Professional Technologist	
Professional Landscape Architect	
Landscape Architect Technician	
Professional Quantity Surveyor	
Quantity Surveyor- Technician	
Sustainability Consultant	
Sustainability Consultant - Technician	
Graphic Designer	

Pricing Schedule Template: DEVELOPMENT OF A DESIGN GUIDELINE FOR THE PLANNING OF POLICE STATIONS

DELIVERABLE	DESCRIPTION	% PAYABLE	TIME FRAME IN WEEKS	ESTIMATED TIME & RATE			COST IN RAND
					TIME IN HOURS	RATE PER HOUR	
Inception Report & Status Quo Report	Inception Report to clarify the scope of works, data assembly aligned with the Project Execution Plan (PEP) & Status Quo report to clarify the current status of documentation available and linking the applicability to the design guideline and align with the Project Execution Plan (PEP)			Project Leader			-
				Professional Architect			-
				Professional Technologist			-
				Professional Landscape Architect			-
				Landscape Architect Technician			-
				Professional Quantity			-
				Quantity Surveyor - Technician			-
				Sustainability Consultant			-
				Sustainability Consultant- Technician			-
				Graphic Designer			-
		#DIV/0!	0	SUB-TOTAL	0		-
Existing policies and guidelines applicable to court planning	Identification and report on existing policies and guidelines that could be applicable to planning			Project Leader			-
				Professional Architect			-
				Professional Technologist			-
				Professional Landscape Architect			-
				Landscape Architect Technician			-
				Professional Quantity Surveyor			-
				Quantity Surveyor - Technician			-
				Sustainability Consultant			-
				Sustainability Consultant- Technician			-
				Graphic Designer			-
		#DIV/0!	0	SUB-TOTAL	0		-
Operational spatial models	Development of operational spatial models for different configurations (figures)			Project Leader			-
				Professional Architect			-
				Professional Technologist			-
				Professional Landscape Architect			-
				Landscape Architect Technician			-
				Professional Quantity Surveyor			-
				Quantity Surveyor - Technician			-
				Sustainability Consultant			-
				Sustainability Consultant- Technician			-
				Graphic Designer			-
		#DIV/0!	0	SUB-TOTAL	0		-
Generic Guidelines	Development clear set of generic guidelines for the planning, design and management of the buildings			Project Leader			-
				Professional Architect			-
				Professional Technologist			-
				Professional Landscape Architect			-
				Landscape Architect Technician			-
				Professional Quantity Surveyor			-
				Quantity Surveyor - Technician			-
				Sustainability Consultant			-
				Sustainability Consultant- Technician			-
				Graphic Designer			-
		#DIV/0!	0	SUB-TOTAL	0		-
Standard material choices and schedules	Development of standard material choices and schedules that could be utilised			Project Leader			-
				Professional Architect			-
				Professional Technologist			-
				Professional Landscape Architect			-
				Graphic Designer			-

				Landscape Architect Technician					
				Professional Quantity Surveyor					
				Quantity Surveyor - Technician					
				Sustainability Consultant					
				Sustainability Consultant-Technician					
				Graphic Designer					
		#DIV/0!	0	SUB-TOTAL	0				
Typical Layouts	Development of typical layouts for specific areas that would be standard within the facility			Project Leader					
				Professional Architect					
				Professional Technologist					
				Professional Landscape Architect					
				Landscape Architect Technician					
				Professional Quantity Surveyor					
				Quantity Surveyor - Technician					
				Sustainability Consultant					
				Sustainability Consultant-Technician					
				Graphic Designer					
		#DIV/0!	0	SUB-TOTAL	0				
Maintenance Strategy	Develop a high level Maintenance Strategy for the building and alignment possibilities with EPWP			Project Leader					
				Professional Architect					
				Professional Technologist					
				Professional Landscape Architect					
				Landscape Architect Technician					
				Professional Quantity Surveyor					
				Quantity Surveyor - Technician					
				Sustainability Consultant					
				Sustainability Consultant-Technician					
				Graphic Designer					
		#DIV/0!	0	SUB-TOTAL	0				
Checklists	Development of checklists for the planning, design and management of the building			Project Leader					
				Professional Architect					
				Professional Technologist					
				Professional Landscape Architect					
				Landscape Architect Technician					
				Professional Quantity Surveyor					
				Quantity Surveyor - Technician					
				Sustainability Consultant					
				Sustainability Consultant-Technician					
				Graphic Designer					
		#DIV/0!	0	SUB-TOTAL	0				
Final Documentation	Submission of Planning Guideline			Project Leader					
				Professional Architect					
				Professional Technologist					
				Professional Landscape Architect					
				Landscape Architect Technician					
				Professional Quantity Surveyor					
				Quantity Surveyor - Technician					
				Sustainability Consultant					
				Sustainability Consultant-Technician					
				Graphic Designer					
		#DIV/0!	0	SUB-TOTAL	0				
Other Items	Specify			SUB-TOTAL					
	1. Graphic design	#DIV/0!	0						
	2. Other	#DIV/0!	0						
	Sub- total of services rendered		0			0	R		
	VAT @ 15%						R		
TOTAL	ESTIMATED HOURS, HOURLY RATE AND TOTAL(S) TO BE CARRIED OVER TO THE ACTIVITY SCHEDULE (C2.2.2) IN THE TENDER DOCUMENT						R		