



public works  
& infrastructure

Department:  
Public Works and Infrastructure  
REPUBLIC OF SOUTH AFRICA

## CONFIRMATION TO UNDERTAKE TENANT INSTALLATION REQUIREMENTS BY THE BIDDER

<b>BID NO</b>	<b>DBN24/01/08</b>
<b>REFERENCE NO</b>	<b>24/2/1/2/17/6306/63</b>
<b>PROJECT TITLE</b>	<b>DEPARTMENT OF HOME AFFAIRS: PROCUREMENT OF OFFICE ACCOMMODATION AND PARKING: PINETOWN LOCAL OFFICE</b>
<b>DATE OF ADVERT</b>	<b>26 JANUARY 2024</b>
<b>CLOSING DATE</b>	<b>22 FEBRUARY 2024</b>

I, the undersigned (Full Name) \_\_\_\_\_ hereby confirm to provide office accommodation as per DPW11.1 (LS Specification on minimum requirements- office accommodation) and undertake/ execute/ implement and effect Tenant Installation requirements at my cost according to the client specification and contribution as per DPW08.3 (LS) Bid Offer- office accommodation.

\_\_\_\_\_  
Signature

\_\_\_\_\_  
Date

\_\_\_\_\_  
Position

\_\_\_\_\_  
Name of bidder



## home affairs

Department:  
Home Affairs  
REPUBLIC OF SOUTH AFRICA

### FINISHING SCHEDULE - REV 3

## 1 Public Area Finishes

### 1.1 Tiling

- 1.1.1. Floor Tiles: Atlas Concorde – Milestone (Canyon) as supplied by Italtile, approved glazed porcelain tile or similarly approved, laid in 45° Pattern with “Goldstar” tile adhesive, with Aluminum formable straight edge code ASE 100 in transition between in public areas and back offices, public areas and main entrance door.
- 1.1.2. Tile Skirting: Atlas Concorde – Milestone (Canyon) as supplied by Italtile, Approved Glazed Porcelain tile or similarly approved, laid in 45° Pattern with “Goldstar” tile adhesive, with polysulphide joint between vertical and horizontal tiles in Public Areas.
- 1.1.3. Wall Tiles: Below Dado Rail: Atlas Concorde – Milestone (Canyon) as supplied by Italtile, approved glazed porcelain tile or similarly approved, laid in 45° Pattern with “Goldstar” tile adhesive, with Aluminum formable straight edge code ASE 100 in transition between in public areas.

### 1.2 Dado Rails

- 1.2.1. On walls: 115x16mm Meranti Moulded Essential Moulding Dado rail Code 92 37 317 Mould N 17, Stained with Mahogany color fixed 1100mm above Finished Floor Level.

### 1.3 Paint

- 1.3.1. Wall Paint: Above Dado Rail: Two coats Dulux Caramel Sand 5 or any similarly approved Plascon Double Velvet colour
- 1.3.2. Ceiling Paint: Gypsum plaster board or suspended ceiling or plastered ceiling. All painted with PVA paint (colour hite) and to be done by Land Lord.
- 1.3.3. Door Paint: Two coats Dulux Caramel Sand 3 or any similarly approved Plascon Double Velvet Colour Caramel Sand 3
- 1.3.4. Door Frames: Two Coats Dulux Colour: Caramel Sand 5 or similarly approved Plascon Double Velvet
- 1.3.5. Steel Windows: Two Coats Dulux Colour: Caramel Sand 5 or similarly approved Plascon Double Velvet

## **1.4 Carpets**

- 1.4.1. Carpets: Nexus Berber Point 920: Senegal range or similarly approved

## **1.5 Blinds:**

- 1.5.1. Windows: Perforated Silver aluminium venetian blind, size to be confirmed on site with 25 x 0,21mm thick slats including 25 x 25mm high matching aluminium powder coated top and bottom tracks with stainless steel separator pins, cord lock and roller pins, and blinds to be face fixed to plastered brickwork.

## **1.6 Counters**

- 1.6.1. Counters as per drawings – Appendix B
- 1.6.2. Tops: Melawood (MLB super wood Substrate) 839 Cherry Royale, with Formica Moss Granite 654 Top
- 1.6.3. Lock: US 20 Center patch lock and US 20 patch lock cover with single throw lock (code DL 810) and lock keeper plate (code DL01/1) finished in polished chrome
- 1.6.4. Hinge: 180° Hinge beveled (code DL 73B/30) and 180° clamp (code 76/3) Finished: Polished chrome
- 1.6.5. Connector: DL76/3 Glass to glass connector Finished: Polished chrome edging.
- 1.6.6. Dividers: 10mm Laminated Safety Glass to be Sand Blasted and to be polished on all edges.

## **1.7 Official Seating**

- 1.7.1. Operator: Operator chair with clutch Mechanism- Gas Height Adjustment- Nylon base castors with Draughtsman's height with p/u non-flexi arms and Black p/u rubber, with a black foot ring, swivel and tilt mechanism upholstered in Vulcan black fabric and p/u base on castors (or similarly approved) for Service counters only.

## **1.8 Writing Ledge Standing**

- 1.8.1. Writing Ledge as per drawing
- 1.8.2. Wood: Melawood (MLB super wood Substrate) 839
- 1.8.3. Tops: Formica Moss Granite 654 Top.

## **1.9 Photo Booth**

- 1.8.1. Layout – Refer to drawing – Appendix C

## 2 Queue Rail System:

- 2.1. Natural Anodized PSG (or Similarly Approved) Post with Black ABS base with Bottle green belt (belt to be minimum 1,8m) Queue Rail system
- 2.2. Natural Anodized PSG (or Similarly Approved) End Post with Black ABS base without belt Queue Rail system

## 3 Signage

- 3.1 Signage: Refer to drawing attached – Appendix D
  - 400 x 460mm New Sand Blast Vinyl Stick on Business Hours decal on shop front
  - 400 x 460mm wall mount slats, V400 Aluminium sign for Business Hours decal foxed to Wall all in accordance with according to vista system – with 2 metal (aluminium) end caps for V400 extrusion Code DHA 100.
  - 798 x 1300 wall mount Price List directory per Services with 2 x Perspex information leaf let all in accordance with Vista System, Code DHA 110:
  - VA4 (215mm/8.42") aluminium sign holder extrusion, Clear Anodize, 800 mm.
  - Clear cover (Non glare on one side) for VA4 extrusion (1mm thick), Glossy/Non glare, 800 mm.
  - 2 Metal (Aluminium) end caps for VA4 extrusion, clear Anodize.
  - V600 (600mm/23.62") aluminium sign holder extrusion, Clear Anodize, 1399 mm.
  - Clear cover for V600 extrusion (2mm thick), Glossy/Non glare, 1399 mm.
  - 2 Metal (Aluminium) end caps for V600 extrusion, clear Anodize.
  - 2 V100 (100mm/3.93") aluminium sign holder extrusions, Clear Anodize, 1399 mm.
  - 2 Clear covers (Non glare on one side) for V100 extrusion (1mm thick), Glossy/Non glare, 1399 mm.
  - 4 Metal (Aluminium) end caps for V100 extrusion, clear Anodize.
- 3.2 This sign is divided into 2 sides

Side 1 contains 33 Black divided strips spaced as follows: 16 units, 52mm height. 16 units, 52mm height. 17 units, 26mm height. 17 units, 26mm height. 1 unit, 26mm height. 1 unit, 26mm height.

Side 2 contains 33 Black divided strips spaced as follows: 16 units, 52mm height. 17 units, 26mm height. 17 units, 26mm height. 1 unit, 26mm height.

  - A4 215 x 350 mm Perspex Poster frame with Translation leaflet in Local Language - DHA 120:
  - VA4 (215mm/8.42") aluminium sign holder extrusion, Clear Anodize, 350 mm.
  - Clear cover (Non glare on one side) for VA4 extrusion (1mm thick), Glossy/Non glare, 50 mm.
  - 2 Metal (Aluminium) end caps for VA4 extrusion, clear Anodize.
  - Black divided strip.
  - VLetterRack-2555 - Clear PETG Rack Letter folded.
  - 150 x 500mm Suspended Service Counter slats Sign all in accordance with Vista system CODE -DHA 130:

- 2 V150 (150mm/5.9") aluminium sign holder extrusions, Clear Anodize, 500 mm.
- 2 Clear covers (Non glare on one side) for V150 extrusion (1mm thick), Glossy/Non glare, 500 mm.
- 2 Stainless steel cable 1.5 mm, 3 Foot.
- 4 Metal (Aluminium) end caps for V150 extrusion, clear Anodize.
- 2 Double sided connectors for V150 (double sided tape included).
- 4 Cable clamps.

This sign to receive a vinyl print of the specific service being offered on the counter, a reference to the counter number and a pictogram of the service being offered.

100 x 400 Sign all in accordance with Vista System - Code DHA 140:

- V400 (400mm/15.74") aluminium sign holder extrusion, Clear Anodize, 100 mm.
- Clear cover for V400 extrusion (1.5mm thick), Glossy/Non glare, 100 mm.
- 2 Metal (Aluminium) end caps for V400 extrusion, clear Anodize.

400 x 2000 Free Standing V400 Tower complete with 2 x A4 Brochure Holder and 1 x A4 Display Holder all mounted on Tower and in accordance with Vista System Code DHA 150:

- 3 V400 (400mm/15.74") aluminium sign holder extrusions, Clear Anodize, 2000 mm.
- 3 Clear covers for V400 extrusion (1.5mm thick), Glossy/Non glare, 2000 mm.
- Metal (Aluminium) end cap for V400 triangle sign, Clear Anodize.
- Metal (Steel) base for triangle design V400 (~15.7"), Black Painted.

215 X 200 New Statutory Indicator Sign all in accordance with Vista system sign to include metal End Cap Code DHA 160:

- VA4 (215mm/8.42") aluminium sign holder extrusion, Clear Anodize, 200 mm.
- Clear cover (Non glare on one side) for VA4 extrusion (1mm thick), Glossy/Non glare, 200 mm.
- 2 Metal (Aluminium) end caps for VA4 extrusion, clear Anodize.

**APPENDIX A – TILES**

# MILESTONE

SIZE RANGE  
GAMMA FORMATI

COLOUR RANGE  
GAMMA COLORI

**PORCELAIN STONEWARE COLOURED IN BODY - RECTIFIED MONOCALIBRE / GRES PORCELLANATO COLORATO IN MASSA - RETTIFICATO MONOCALIBRO**  
**GRÉS CÉRAMÉ COLORÉ DANS LA MASSE - RECTIFIÉ MONO-CALIBRE / DURCHGETRÄGTES FEINSTEINZUG - GESCHLIFFEN EINKALIBRIG**  
**GRES PORCELÁNICO COLOREADO EN MASA - RECTIFICADO MONOCALIBRE / НЕПРЯМОЕ ЖЕЛТО ГРАНИТ ОКРАШЕННЫЙ В МАССЕ - РЕТИРОВАНО ПОБЛИЖЕНО К ОДНОМУ КАЛИБРУ**

## MATT

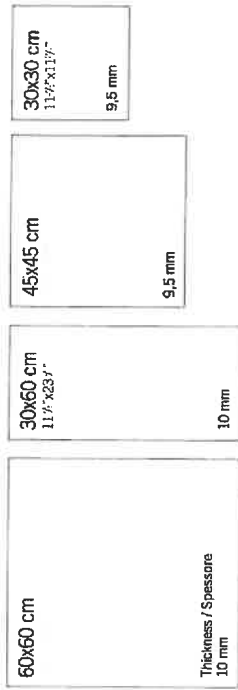

## HONED, LAPPATO.

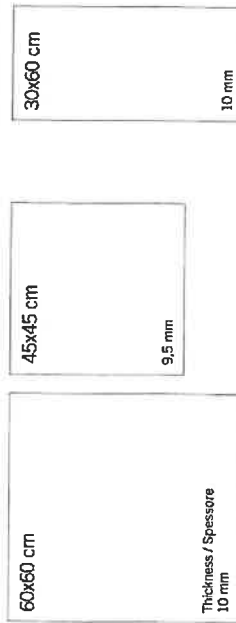

## TEXTURED, STRUTTURATO.



MILESTONE DESERT



MILESTONE ALASKA



MILESTONE CANYON



MILESTONE CLIFF

# MILESTONE

## SIZE AND SURFACES RANGE GAMMA FORMATI E SUPERFICI



### MILESTONE ALASKA

### MILESTONE DESERT

### MILESTONE CANYON

### MILESTONE CLIFF

MATT  
MATT

HONED  
LAPPATO

TEXTURED  
STRUTTURATO

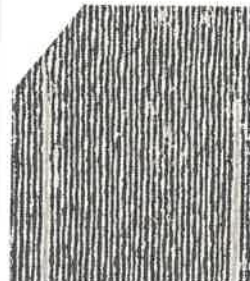
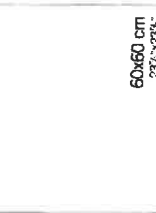
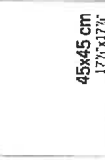

60x60 cm  
23 1/4" x 23 1/4"

30x60 cm  
11 5/8" x 23 1/4"

45x45 cm  
17 3/4" x 17 3/4"

30x30 cm  
11 5/8" x 11 5/8"

60x60 cm  
23 1/4" x 23 1/4"

45x45 cm

30x60 cm  
11 5/8" x 23 1/4"



**MILESTONE** COLOUR-SHADING  
STONALIZZAZIONE



**ALASKA**

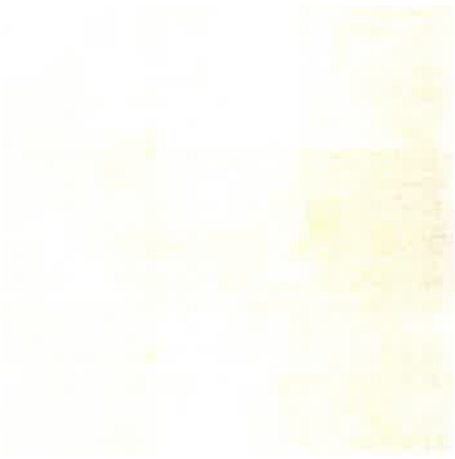

45x45 cm / 17 3/4" x 17 3/4"

V3

**DESERT**



45x45 cm / 17 3/4" x 17 3/4"

V3

**CANYON**



45x45 cm / 17 3/4" x 17 3/4"

V3

**CLIFF**

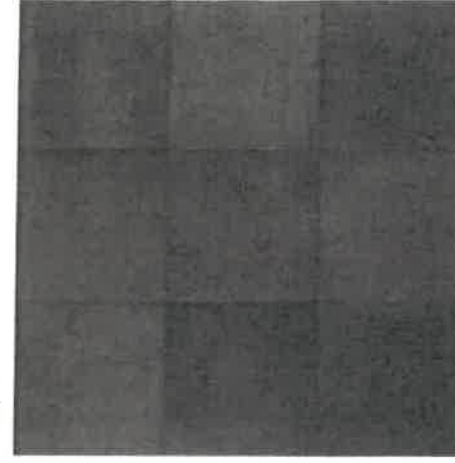

45x45 cm / 17 3/4" x 17 3/4"

V3

**NOTES**  
**NOTE**

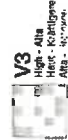
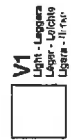
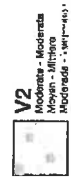



**MILESTONE**

Technical features - conforme alla norma EN 14481 (ISO 13006) Annex G Gruppo B1a  
 Características técnicas - en conformidad con la Norma EN 14481 (ISO 13006) Anexo G Grupo B1a

Nome	Requisito	Valore	Unità	Test	Metodo	Classe
Resistenza chimica	Resistenza agli acidi e ai sali	> 1000 h	h	RECHISE	RECHISE	RECHISE
Resistenza meccanica	Resistenza alle sollecitazioni statiche e dinamiche	> 45 MPa	MPa	RECHISE	RECHISE	RECHISE
Resistenza agli urti	Resistenza agli urti dinamici	≥ 150 mJ	mJ	RECHISE	RECHISE	RECHISE
Resistenza all'abrasione	Resistenza all'abrasione	< 0,5 mg	mg	RECHISE	RECHISE	RECHISE
Resistenza all'inquinamento	Resistenza all'inquinamento	> 0,40	-	RECHISE	RECHISE	RECHISE

**MADE IN ITALY**

The Made in Italy logo of Atlas Concorde is an exclusive identification of the Made in Italy products, which have been effectively made in Italy by companies that are a part of the Confindustria Ceramica. Ceramica, contains all companies to communitatis, clearly and with transparency, the origin of their products.

**The European logo of environmental quality certifies compliance with the European environmental criteria and is only given to products that, compared to those of competitors, have a low environmental impact. EcoLabel is a quality award that identifies and promotes products with a low environmental impact. The environmental criteria evaluate the impact on the entire lifecycle of the product, from raw material extraction, production, distribution, use until final disposal.**

Il marchio Concorde Qualità Certifica l'eco-compatibilità dei prodotti ceramici. I prodotti eco-compatibili hanno un basso impatto ambientale. EcoLabel è un premio di qualità che identifica e promuove i prodotti più ecologici e rispettosi dell'ambiente. I criteri ambientali valutano l'impatto ambientale di un prodotto durante tutto il ciclo di vita, dalla estrazione delle materie prime, processi di lavorazione, distribuzione, utilizzo, manutenzione.

**The Made in Italy logo of Atlas Concorde is an exclusive identification of the Made in Italy products, which have been effectively made in Italy by companies that are a part of the Confindustria Ceramica. Ceramica, contains all companies to communitatis, clearly and with transparency, the origin of their products.**

Il marchio Concorde di alta tecnologia certifica la compatibilità dei prodotti ceramici con l'ambiente. I prodotti eco-compatibili hanno un basso impatto ambientale. EcoLabel è un premio di qualità che identifica e promuove i prodotti più ecologici e rispettosi dell'ambiente. I criteri ambientali valutano l'impatto ambientale di un prodotto durante tutto il ciclo di vita, dalla estrazione delle materie prime, processi di lavorazione, distribuzione, utilizzo, manutenzione.

**Milestones in Italy**... **Il marchio Made in Italy di Atlas Concorde è un segno di qualità, qualità ed stile, garantito con la provenienza italiana dei prodotti.**

Il marchio Made in Italy di Atlas Concorde è un segno di qualità, qualità ed stile, garantito con la provenienza italiana dei prodotti.

**Il marchio Made in Italy di Atlas Concorde è un segno di qualità, qualità ed stile, garantito con la provenienza italiana dei prodotti.**

**Milestones in Italy**... **Il marchio Made in Italy di Atlas Concorde è un segno di qualità, qualità ed stile, garantito con la provenienza italiana dei prodotti.**

Il marchio Made in Italy di Atlas Concorde è un segno di qualità, qualità ed stile, garantito con la provenienza italiana dei prodotti.

**Il marchio Made in Italy di Atlas Concorde è un segno di qualità, qualità ed stile, garantito con la provenienza italiana dei prodotti.**

**The European logo of environmental quality certifies compliance with the European environmental criteria and is only given to products that, compared to those of competitors, have a low environmental impact. EcoLabel is a quality award that identifies and promotes products with a low environmental impact. The environmental criteria evaluate the impact on the entire lifecycle of the product, from raw material extraction, production, distribution, use until final disposal.**

Il marchio EcoLabel certifica la compatibilità dei prodotti ceramici con l'ambiente. I prodotti eco-compatibili hanno un basso impatto ambientale. EcoLabel è un premio di qualità che identifica e promuove i prodotti più ecologici e rispettosi dell'ambiente. I criteri ambientali valutano l'impatto ambientale di un prodotto durante tutto il ciclo di vita, dalla estrazione delle materie prime, processi di lavorazione, distribuzione, utilizzo, manutenzione.

**The European logo of environmental quality certifies compliance with the European environmental criteria and is only given to products that, compared to those of competitors, have a low environmental impact. EcoLabel is a quality award that identifies and promotes products with a low environmental impact. The environmental criteria evaluate the impact on the entire lifecycle of the product, from raw material extraction, production, distribution, use until final disposal.**

Il marchio EcoLabel certifica la compatibilità dei prodotti ceramici con l'ambiente. I prodotti eco-compatibili hanno un basso impatto ambientale. EcoLabel è un premio di qualità che identifica e promuove i prodotti più ecologici e rispettosi dell'ambiente. I criteri ambientali valutano l'impatto ambientale di un prodotto durante tutto il ciclo di vita, dalla estrazione delle materie prime, processi di lavorazione, distribuzione, utilizzo, manutenzione.

**The European logo of environmental quality certifies compliance with the European environmental criteria and is only given to products that, compared to those of competitors, have a low environmental impact. EcoLabel is a quality award that identifies and promotes products with a low environmental impact. The environmental criteria evaluate the impact on the entire lifecycle of the product, from raw material extraction, production, distribution, use until final disposal.**

Il marchio EcoLabel certifica la compatibilità dei prodotti ceramici con l'ambiente. I prodotti eco-compatibili hanno un basso impatto ambientale. EcoLabel è un premio di qualità che identifica e promuove i prodotti più ecologici e rispettosi dell'ambiente. I criteri ambientali valutano l'impatto ambientale di un prodotto durante tutto il ciclo di vita, dalla estrazione delle materie prime, processi di lavorazione, distribuzione, utilizzo, manutenzione.

**The European logo of environmental quality certifies compliance with the European environmental criteria and is only given to products that, compared to those of competitors, have a low environmental impact. EcoLabel is a quality award that identifies and promotes products with a low environmental impact. The environmental criteria evaluate the impact on the entire lifecycle of the product, from raw material extraction, production, distribution, use until final disposal.**

Il marchio EcoLabel certifica la compatibilità dei prodotti ceramici con l'ambiente. I prodotti eco-compatibili hanno un basso impatto ambientale. EcoLabel è un premio di qualità che identifica e promuove i prodotti più ecologici e rispettosi dell'ambiente. I criteri ambientali valutano l'impatto ambientale di un prodotto durante tutto il ciclo di vita, dalla estrazione delle materie prime, processi di lavorazione, distribuzione, utilizzo, manutenzione.

**APPENDIX B – COUNTER DRAWINGS**

**GENERAL NOTES & SPECIFICATIONS**

SEE OTHER SPECIFICATIONS AND NOTES FOR MATERIALS AND FINISHES.

ALL DIMENSIONS UNLESS OTHERWISE NOTED ARE IN MILLIMETERS.

CONTRACTOR SHALL VERIFY ALL DIMENSIONS AND FINISHES BEFORE PROCEEDING WITH WORK.

NO PARTS TO BE SUBSTITUTED WITHOUT WRITTEN APPROVAL OF ARCHITECT.

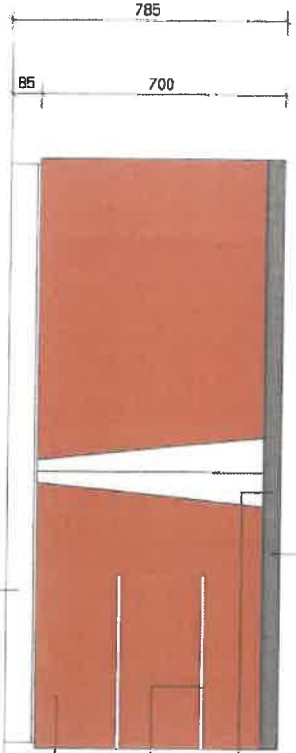

**ELEVATION B-B**  
SCALE 1:20

COUNTER TOP WITH FORMICA  
MOSS GRANITE

FORMICA MOSS GRANITE TOP

10 X 3mm NATURAL ANODISED ALUM. STRIP  
GLUED IN, 3mm EDGE EXPOSED AND  
PROJECTING 4mm (CORNERS TO BE ROUNDED).

MFB HELLAWOOD WITH SUPAWOOD SUBSTRATE,  
CHERRY ROYALE FINISH

76 X 1.9mm NATURAL ANODISED  
ALUMINIUM SKIRTING

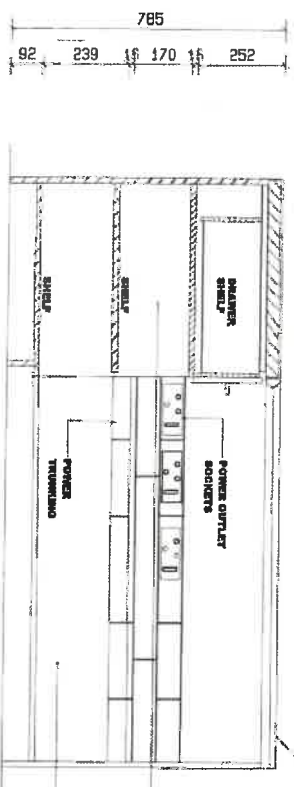

**SECTIONAL ELEVATION A-A**  
SCALE 1:40

COUNTER TOP WITH FORMICA  
MOSS GRANITE

CREDENZA UNIT

MFB HELLAWOOD WITH SUPAWOOD SUBSTRATE,  
CHERRY ROYALE FINISH

SYMBOL	DESCRIPTION
1	ALUMINIUM SKIRTING
2	FORMICA MOSS GRANITE TOP
3	10 X 3mm NATURAL ANODISED ALUM. STRIP
4	MFB HELLAWOOD WITH SUPAWOOD SUBSTRATE, CHERRY ROYALE FINISH

REV	DATE	DESCRIPTION



PROJECT: MFB HELLAWOOD WITH SUPAWOOD SUBSTRATE, CHERRY ROYALE FINISH

DATE: 2024-01-15

SCALE: 1:40

CONTRACTOR: DHA 011

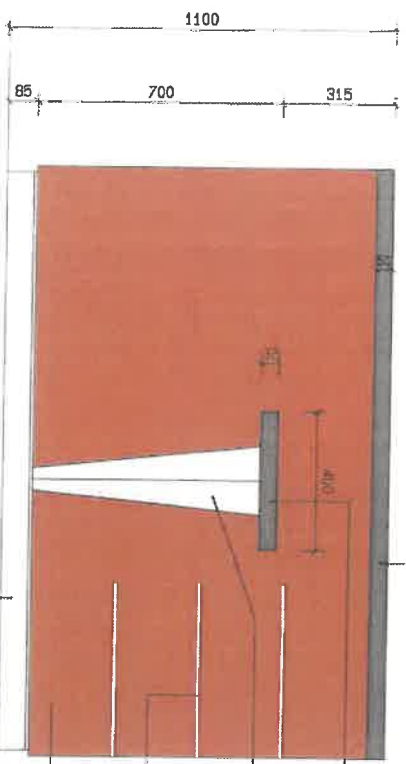

COUNTER TOP WITH FORMICA  
MOSS GRANITE

FORMICA MOSS GRANITE TOP

MILD STEEL HANDBAG LEDGE ANGLE SUPPORT  
POWDER COATED PLASCON BNG 1051 BRIGHT  
ALUMINIUM.

10 x 3mm NATURAL ANODISED ALUM. STRIP  
GLUED IN, 3mm EDGE EXPOSED AND  
PROJECTING 4mm(CORNERS TO BE ROUNDED).

MFB MELLAWOOD WITH SUPAWOOD SUBSTRATE,  
CHERRY ROYALE FINISH

76 X 1.9mm NATURAL ANODISED  
ALUMINIUM SKIRTING

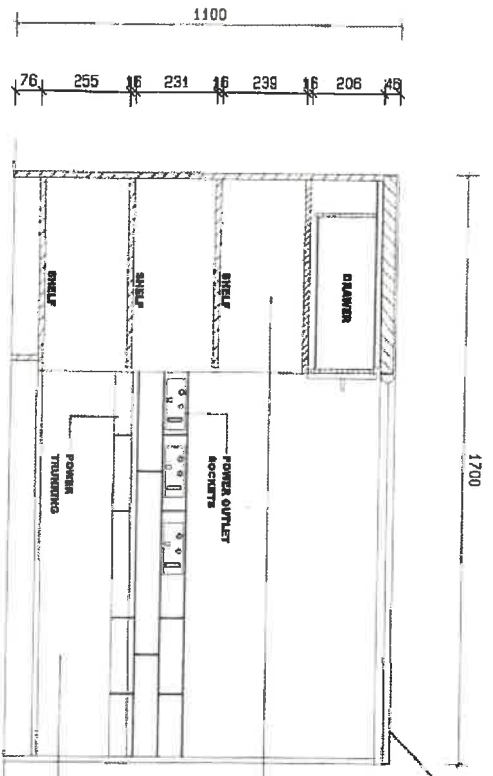

COUNTER TOP WITH  
FORMICA  
MOSS GRANITE

CREDENZA UNIT FIXED  
TO DESK WITH 45 X  
45 X 4mm ANGLE  
BRACKET  
(200mm LONG)

MFB MELLAWOOD WITH SUPAWOOD SUBSTRATE,  
CHERRY ROYALE FINISH

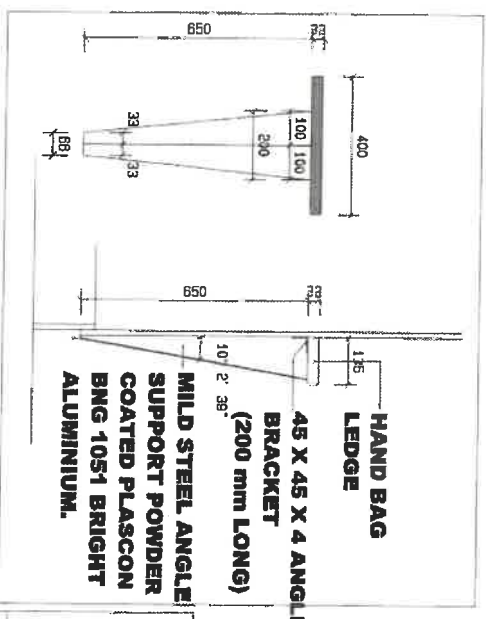

HAND BAG  
LEDGE  
45 X 45 X 4 ANGLE  
BRACKET  
(200 mm LONG)

MILD STEEL ANGLE  
SUPPORT POWDER  
COATED PLASCON  
BNG 1051 BRIGHT  
ALUMINIUM.

**GENERAL NOTES & SPECIFICATIONS**  
SEE OTHER SPECIFICATIONS ATTACHED AND RELATED SPECIFICATIONS  
ALL DIMENSIONS SHOWN IN DIMENSIONS OF THE CONTRACT  
DRAWINGS UNLESS OTHERWISE SPECIFIED.  
CONTRACTOR SHALL VERIFY ALL DIMENSIONS AND MATERIALS  
AND FINISHES TO BE USED.  
THE CONTRACTOR SHALL BE RESPONSIBLE FOR OBTAINING ALL NECESSARY  
PERMITS AND APPROVALS FROM THE LOCAL AUTHORITIES.

SYMBOL	DESCRIPTION
	FORMICA MOSS GRANITE
	MILD STEEL HANDBAG LEDGE
	POWDER COATED PLASCON BNG 1051 BRIGHT ALUMINIUM
	MFB MELLAWOOD WITH SUPAWOOD SUBSTRATE
	76 X 1.9mm NATURAL ANODISED ALUMINIUM SKIRTING



WARRANTY  
EXHIBITION ROOM LAYOUT RECEPTION AREA  
FOR MFB MELLAWOOD WITH SUPAWOOD SUBSTRATE, CHERRY ROYALE FINISH

DATE	SCALE	PROJECT
10/10/21	1:10	EXHIBITION ROOM LAYOUT RECEPTION AREA

**SECTIONAL ELEVATION A-A**  
SCALE 1:10

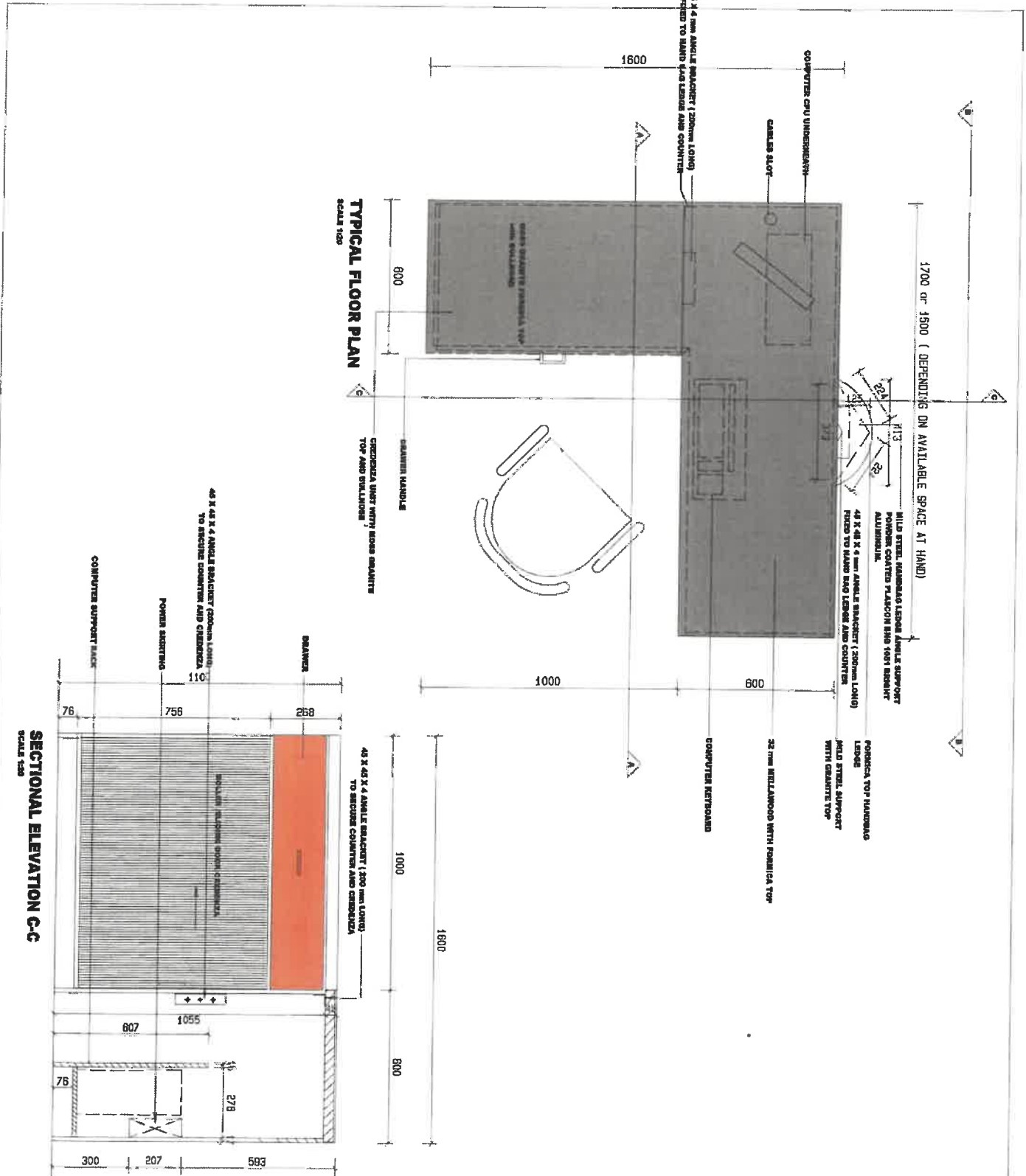

**TYPICAL FLOOR PLAN**  
SCALE 1:50

**SECTIONAL ELEVATION C-C**  
SCALE 1:50

**GENERAL NOTES & SPECIFICATIONS**

1. ALL DIMENSIONS UNLESS OTHERWISE SPECIFIED ARE IN MILLIMETERS.

2. ALL DIMENSIONS SHALL BE TO FACE UNLESS OTHERWISE SPECIFIED.

3. MATERIALS SHALL BE AS SPECIFIED IN THE BILL OF MATERIALS.

4. FINISHES SHALL BE AS SPECIFIED IN THE BILL OF MATERIALS.

5. THE CONTRACTOR SHALL BE RESPONSIBLE FOR OBTAINING ALL NECESSARY PERMITS AND APPROVALS FROM THE LOCAL AUTHORITIES.

NO.	DATE	REVISION
1		
2		
3		
4		
5		
6		
7		
8		
9		
10		
11		
12		
13		
14		
15		
16		
17		
18		
19		
20		
21		
22		
23		
24		
25		
26		
27		
28		
29		
30		
31		
32		
33		
34		
35		
36		
37		
38		
39		
40		
41		
42		
43		
44		
45		
46		
47		
48		
49		
50		



PROJECT: TYPICAL FLOOR LAYOUT SECTION A-B  
 DRAWING NO: DHA\_010A  
 DATE: 15/07/11

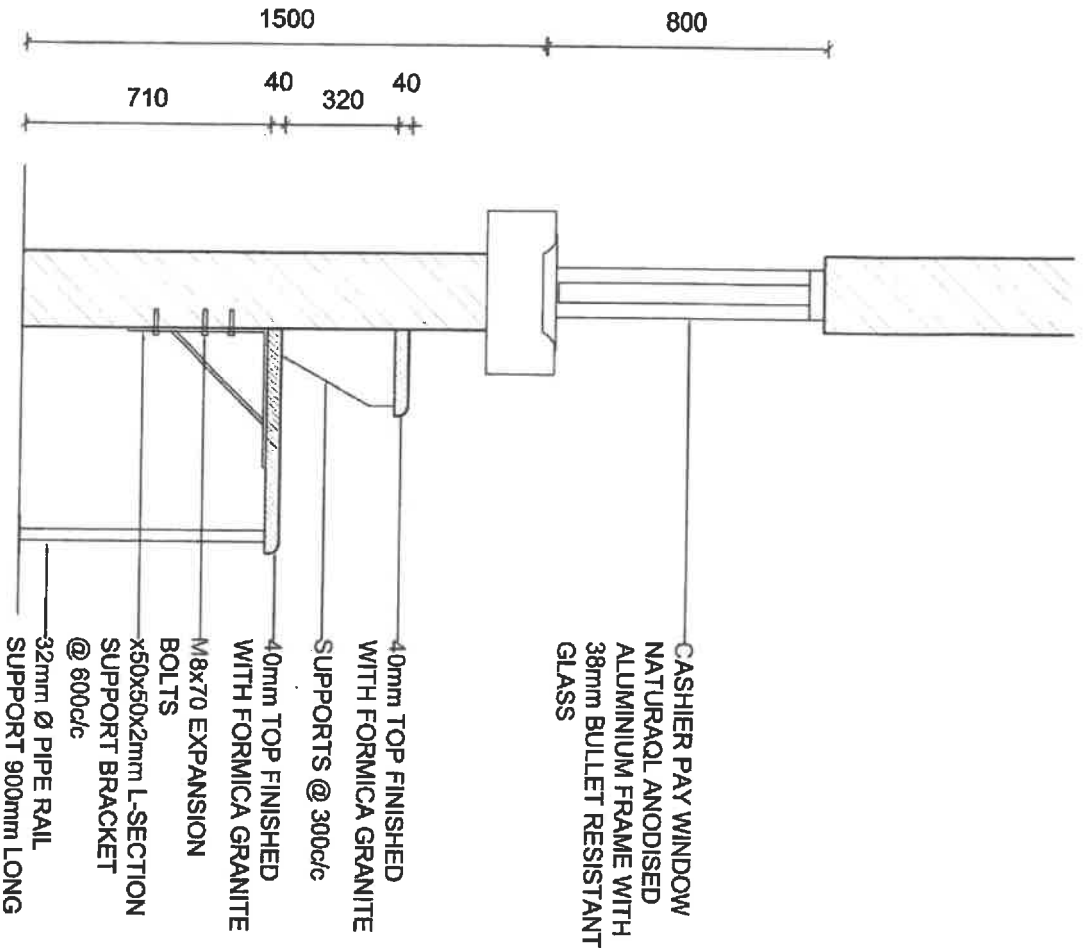

# DETAIL: CASHIER COUNTER

SCALE 1:20

**DEPARTMENT OF**

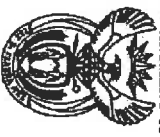

**HEAD OFFICE**  
Corner Maggs &  
Petroleum Street  
Waltloo  
Pretoria

Postal Address:  
Dept. of Home Affairs  
Private Bag X114  
Pretoria  
0001

Tel: (012) 810 8323

**HOME AFFAIRS**

consultant



**Ginzani**  
ENGINEERING CONSULTANTS

PRETORIA  
Telephone (012) 345 3393

**DEPARTMENT  
HOME AFFAIRS**

Drawing title

**DETAIL:  
CASHIER  
COUNTER**

rel.no	designed
scale 1:20	drawn NK
date 21/02/2010	checked
Type number	
drawing number	REV No <b>2</b>

**APPENDIX C – PHOTO BOOTH DRAWING**



FOR CONSTRUCTION

NO	DATE	REVISED	SIGN

Copyright vests in the Department of Home Affairs

cab: file name

DEPARTMENT



Postal Address:  
Dept. of Home Affairs  
Private Bag 1114  
Pretoria  
0001

consultant



PRETORIA  
Telephone (012) 346 3383

DEPARTMENT  
HOME AFFAIRS

drawing title

BOOTH DETAIL

rel.no	designer
scale	drawn by
date	checked
type number	key no

LEGEND	
	1/2 way CLEAN PLUG POINT - INDICATED RED PLUG
	1/6 way PLUG POINT
	IT POINT
	POWER SOCKETS & COMPONENTS COMPLETE WITH EXTERNAL REELS AND END COVERS

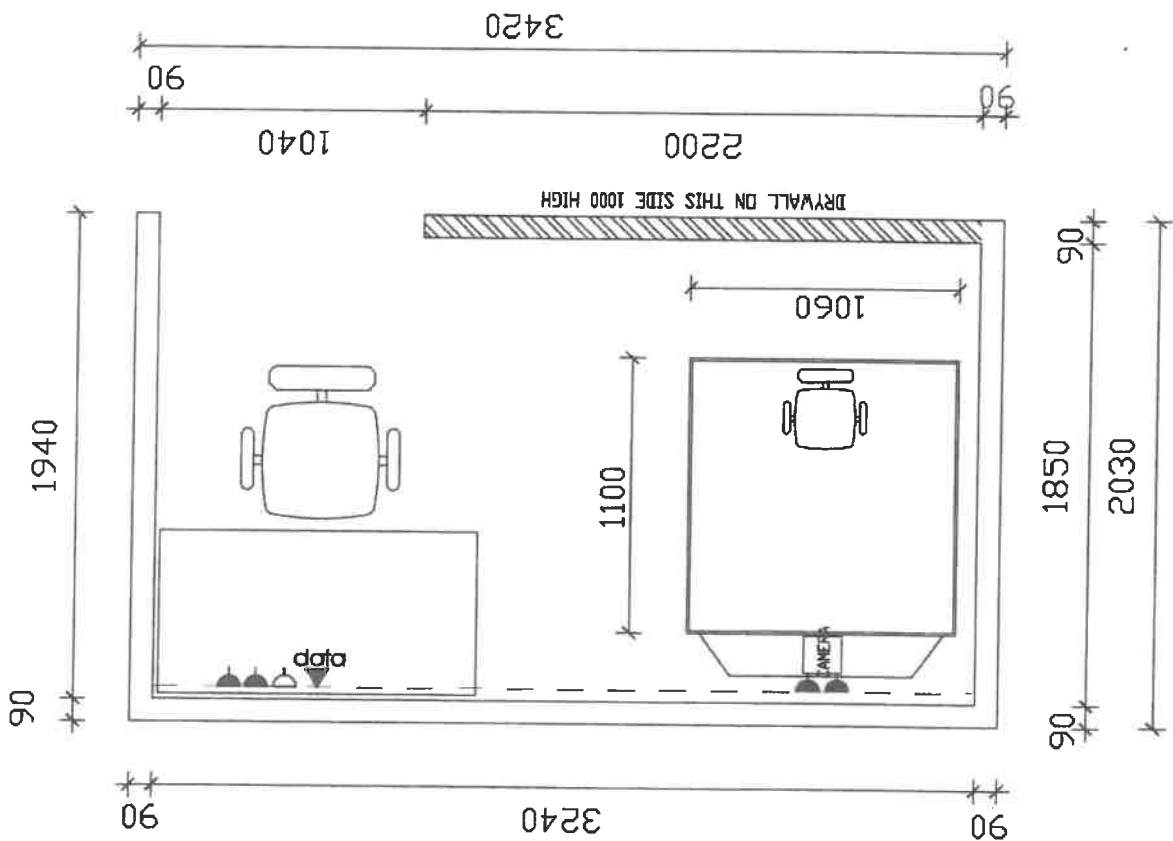

PHOTO BOOTH DETAIL  
SCALE 1:50

APPENDIX D - SIGNAGE

150 x 500mm SUSPENDED SERVICE COUNTER SLATS  
SIGN ALL IN ACCORDANCE WITH VISTA SYSTEM  
CODE DHA 130



**SUSPENDED  
COUNTER SIGN**

A4 DISPLAY POCKETS

A4 DISPLAY POCKETS

400 x 300mm FREE STANDING V400 TONER COMPLETE WITH 2 x M4  
BROCHURE HOLDER AND 1 x M4 DISPLAY HOLDER ALL MOUNTED TO  
TONER AND IN ACCORDANCE WITH VISTA SYSTEM CODE DHA 150

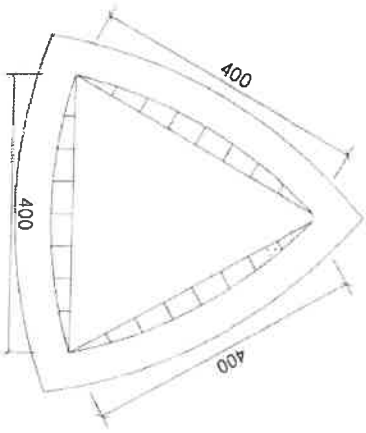

**INFORMATION PILLAR (V400)**

V400



home affairs  
Department:  
Home Affairs  
REPUBLIC OF SOUTH AFRICA

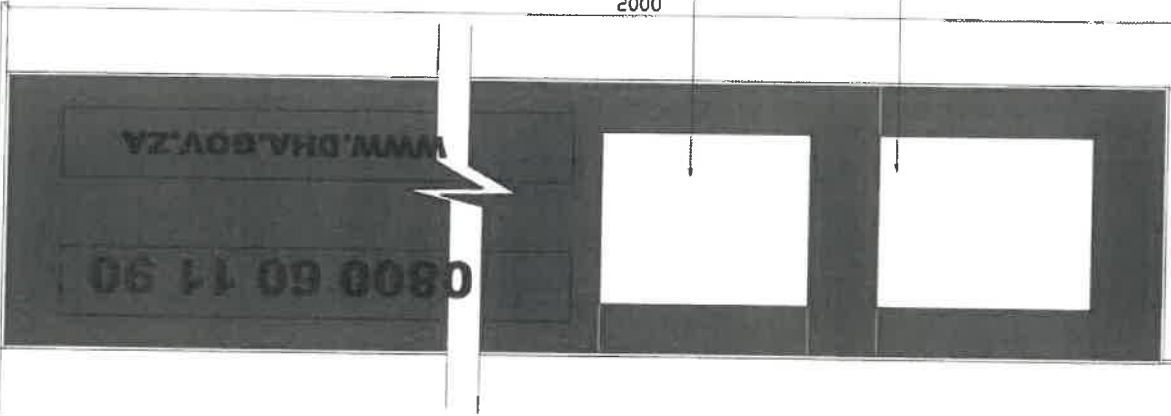

798



home affairs  
Department:  
Home Affairs  
REPUBLIC OF SOUTH AFRICA

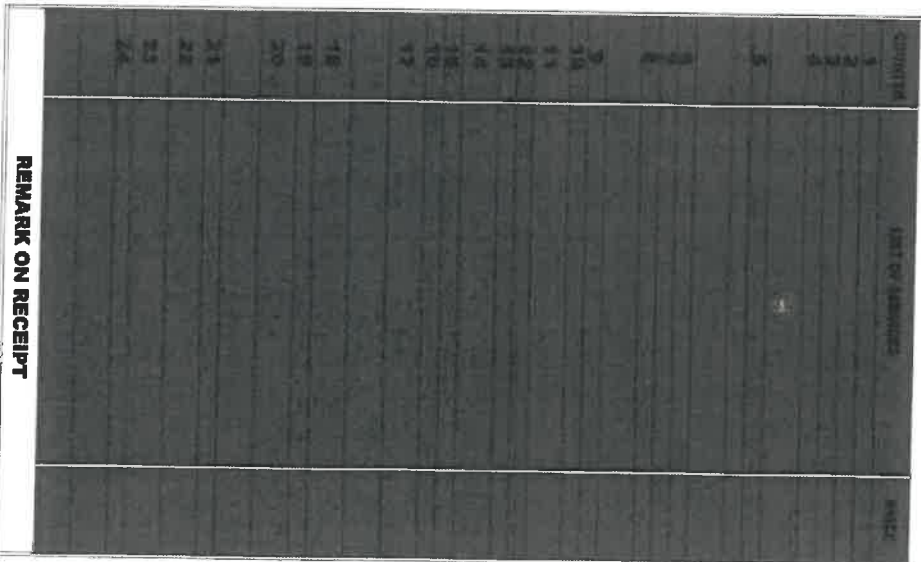

REMARK ON RECEIPT

798 x 1300mm WALL MOUNT PRICE LIST DIRECTION FOR SERVICES WITH 2 x PERBEX  
INFORMATION LEFT LET ALL IN ACCORDANCE WITH VISTA SYSTEM - CODE DHA 110

**PRICE LIST BOARD**

**GENERAL NOTES & SPECIFICATIONS**  
THE CLIENT AGREES TO ACCEPT THE PRICE LIST BOARD AS SUPPLIED BY THE CONTRACTOR  
ALL DIMENSIONS ARE IN MILLIMETRES UNLESS OTHERWISE SPECIFIED  
THE CONTRACTOR SHALL BE RESPONSIBLE FOR OBTAINING ALL NECESSARY PERMITS AND APPROVALS  
ALL DIMENSIONS SHALL BE TO FACE UNLESS OTHERWISE SPECIFIED  
THE CONTRACTOR SHALL BE RESPONSIBLE FOR OBTAINING ALL NECESSARY PERMITS AND APPROVALS

NO.	DATE	DESCRIPTION
1		
2		
3		
4		
5		
6		
7		
8		
9		
10		
11		
12		
13		
14		
15		
16		
17		
18		
19		
20		
21		
22		
23		
24		



DATE 1  
DATE 2  
DHA 031

## ANTI BANDIT DOORS

Level	Classification	Description
G1	Handguns up to and including 9mm Parabellum	No view panel. Internal application
G1	Handguns up to and including 9mm Parabellum	View panel - 28mm glass. Internal application
G2	Handguns up to and including .357 Magnum as well as 12 gauge shotgun firing buckshot	No view panel. Internal application
G2	Handguns up to and including .357 Magnum as well as 12 gauge shotgun firing buckshot	View panel - 38mm glass. Internal application
G3	AK 47 assault rifle up to and including 12 gauge shotgun firing Brenneke slugs.	No view panel. Internal application
G3	AK 47 assault rifle up to and including 12 gauge shotgun firing Brenneke slugs.	View panel - 53mm glass. Internal application.

Purpose made bullet resistant doors, manufactured with 100mm x 50mm x 2mm mild steel frame, supplied with a 5 pin CISA dead lock, continuous roton type hinge, aluminum slam bar and D-style pull handles

### Optional Extras

- ▶ External Doors
- ▶ Non Standard doors
- ▶ Stainless steel / aluminum kick/push plates (4 per door)
- ▶ Door closure - light duty TS72
- ▶ Door closure - heavy duty TS91
- ▶ Magnetic lock - light duty (200kg)
- ▶ Magnetic lock - heavy duty (500kg)
- ▶ 6 Amp power supply
- ▶ Key switch and surface mounted casing
- ▶ Push buttons
- ▶ Interlock system
- ▶ Adams-rite electronic lock & stricker
- ▶ Frame - 2095mm H x 930mm W
- ▶ Wall Opening - 2105mm H x 940mm W

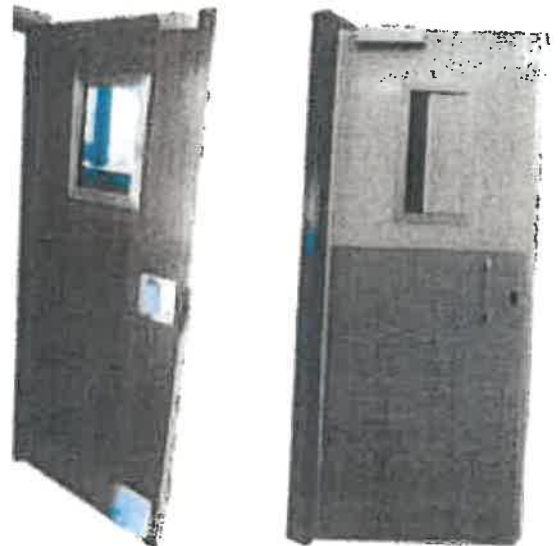

Special door sizes and configurations are available on request.

## PAY WINDOWS

- ▶ Choice of locking and entry systems
- ▶ Ballistic Protection
- ▶ Easy installation
- ▶ Provides extra protection against physical attack
- ▶ Designed for locating at staff entrances
- ▶ Constructed to ward off determined raiders / intruders



### Window Type 1 Shallow Trays - PWI Classification

#### Level Classification

- |    |  |
|----|--|
| G1 | Handguns up to and including 9mm Parabellum  |
| G2 | Handguns up to and including .357 Magnum as well as 12 gauge shotgun firing buckshot |
| G3 | AK 47 assault rifle up to and including 12 gauge shotgun firing Brenneke slugs       |

#### Description

- |   |
|---|
| Purpose made bullet resistant pay window glazed in 28mm glass |
| Purpose made bullet resistant pay window glazed in 38mm glass |
| Purpose made bullet resistant pay window glazed in 53mm glass |

All windows supplied with natural anodized aluminum frame and 32mm post formed oak counter top fitted with a 19mm deep stainless steel dish tray.

#### Type 1

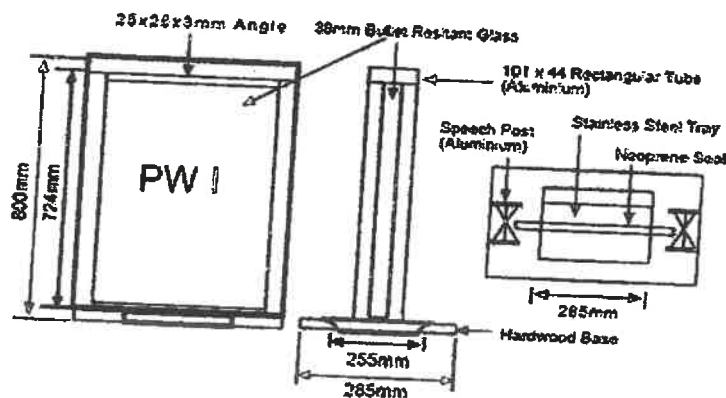

#### Optional Extras

- ▶ Non-Standard Windows
- ▶ Special counter finishes
- ▶ Exterior stainless steel counter finish- standard window
- ▶ Grey tinted glass
- ▶ S10 silver tinted reflective glass (one way)

#### Window size

- ▶ 800mm H x 600mm W

#### Wall opening

- ▶ 810mm H x 610mm W

DEPARTMENT OF HOME AFFAIRS

SPECIFICATION

FOR

AIR CONDITIONING AND

VENTILATION INSTALLATIONS

## STANDARD SPECIFICATION

FOR

## AIR CONDITIONING AND VENTILATION INSTALLATIONS

### SECTION 4

#### 4.0 TECHNICAL REQUIREMENTS - EQUIPMENT AND MATERIALS

##### 4.1.0 ROOM TYPE AIR CONDITIONERS - AIR COOLED

##### 4.1.1 General

4.1.1.1 Room type air conditioners shall be completely self-contained units of the direct expansion unitary or split type design, air-cooled.

4.1.1.2 The air conditioners shall generally be in accordance with SABS 1125-1977 with sound levels not exceeding the values specified in the Supplementary Specification and/or this Standard Specification as applicable.

4.1.1.3 Room air side shall be equipped with a suitable and easily accessible filter, two speed fan, adjustable directional air discharge grille, adjustable outside air intake damper, control thermostat, electric heating elements (if not specified as reverse cycle heating) (where applicable), drain pan and drain piping, cooling coil, controls and control panel and complete wiring, including interlocking with outdoor unit.

4.1.1.4 The outdoor unit shall contain the matching compressor unit, air-cooled condenser, condenser fan within a waterproof painted and corrosion protected casing.

4.1.1.5 The indoor/outdoor units shall be interconnected with refrigerant piping (separately insulated suction and delivery piping for reverse cycle units), electric wiring and interlocking control cabling.

Where visible and/or exposed to the weather or possible mechanical damage refrigerant piping and cabling shall be run inside galvanised sheet steel trunking, neatly erected and painted as specified.

4.1.1.6 Where applicable provision shall be made in the unit design to re-evaporate condensate from the condenser.

Provision shall however be made in all cases for the drainage of excessive condensate to the nearest building drain by means of copper or uPVC tubing (refer to Supplementary Specification) not less than 18mm diameter.

For reverse cycle heating units, including split type units, a proper dripan with drainage piping as above shall be provided for the outdoor units where dripping can create unacceptable conditions.

Where drainage piping is required to be installed flush mounted, positioning and chasing shall be done in good time to meet construction programmes.

Drainage to points other than a proper building drain shall comply with SABS 0400.

4.1.1.7 All panels shall be neat fitting with hardwearing exposed surfaces of baked enamel or equal finish of approved colour.

- 4.1.1.8 Electrical interlocking shall be provided to ensure that;
- a) compressor cannot run without both indoor and outdoor fans running,
  - b) electric heating elements can only be switched on if the indoor fan is running,
  - c) it shall not be possible to switch cooling and heating on simultaneously.
- 4.1.1.9 Unless otherwise specified in the Supplementary Specification room type air conditioners in the cooling mode shall be rated at 35°C ambient dry bulb air temperature on to the condenser, 27°C dry bulb and 19°C wet bulb air entering conditions to evaporator, all at sea level with the cooling capacities specified at these conditions. For reverse cycle heating the rating shall be based on 7°C ambient dry bulb and 6°C wet bulb air on to the outdoor coil with 21°C dry bulb air on to the indoor coil.
- 4.1.1.10 Unless otherwise detailed on the drawings or in the Supplementary Specification units installed through a wall shall be installed with a subframe built in to the wall (hardwood or steel) and neat finishing architraves inside and outside. The external architrave shall be of aluminium angle and shall be mitred at corners and shall cover the subframe and opening completely. The architrave and subframe surround shall be sealed with clear silicone sealant.
- 4.1.2 Coastal Applications
- For coastal applications special considerations and requirements are called for namely;
- 4.1.2.1 All steel parts exposed to the atmosphere or to ambient air (including outdoor unit air path) shall be either hot-dip galvanised or electroplated to SABS 728 of 1970 before painting.
- 4.1.2.2 Outdoor unit coil shall be constructed of copper to copper tubing and fins.
- 4.1.2.3 Electric terminals and connections shall be corrosion protected with non-hardening mastic or equal coating.
- 4.1.2.4 The complete compressor unit shall be sprayed with a continuous skin of PA 10 plastic film, or equal.
- 4.1.2.5 Fan motors, fan scroll and internal fan wheels shall similarly be sprayed with a PA 10 plastic film or equal.
- 4.1.3 Window Type Units
- 4.1.3.1 Window type room air conditioners shall be suitable for mounting in window frames or wall openings and shall be completely self-contained.
- 4.1.3.2 The units shall be made up in two parts namely the chassis or cabinet and the main body. The cabinet shall be mounted in the window frame or wall. The main body shall slide in/out on self-locating guides and guide strips to facilitate maintenance.
- 4.1.3.3 Where a unit is installed beyond normal reach the controls shall be installed remote at eye level.
- Unless otherwise specified in the Supplementary Specification all wiring between the unit and the remote control shall be installed in flush conduit and draw-boxes.



4.1.4 Console Type Units

4.1.4.1 Console units shall be completely self-contained and shall be mounted above skirting height for cleaning purposes.

4.1.4.2 Units with a two-part construction allowing the cabinet to be built in to the wall with the main body to slide in or out is preferred.

4.1.4.3 Matching weather tight air intake and exhaust louvred panels of anodised aluminium with horizontal blades shall be provided and installed with each unit.

Depending on size, detail and wall thickness the louvre shall form part of the cabinet or shall be fixed to the subframe.

4.1.4.4 Units shall be supplied with the manufacturer's standard 2 kW electric heating element thermostatically controlled.

Reverse cycle units shall only be supplied if called for in the Supplementary Specification.

4.1.5 Split Type Units

4.1.5.1 Split type units shall consist of a direct expansion indoor fan coil unit and a separate (remote) externally located air-cooled condensing unit.

4.1.5.2 The indoor fan coil unit shall be floor-mounted, wall mounted, under-ceiling mounted, ceiling cassette mounted or above ceiling ducted type as specified.

4.1.5.3 Above ceiling units shall be properly insulated, particularly where exposed to high roof or lighting heat loads.

4.1.5.4 Remote controls shall be wired in conduit and mounted at eye level in the positions indicated on the drawings.

4.1.5.5 All conduit and draw boxes shall be installed flush in the walls or partitions.

Surface mounted wiring in trunking or the like will only be accepted if specified as such. No joints will be allowed in the control wiring.

4.1.5.6 Suction lines shall be insulated as specified. Suction and delivering lines may not be insulated grouped together as for a single line. Vapour barrier integrity will be critical to prevent dripping.

4.1.5.7 Gas piping (insulated as specified) and wiring shall be installed in galvanised steel trunking throughout for protection, painted as specified where exposed or visible.

4.1.5.8 Outdoor units shall be installed on raised plinths or where wall mounted on unistrut or approved galvanised steel brackets, properly braced and fixed.

4.1.5.9 Refrigerant piping shall be sized and fitted with the necessary oil traps strictly in accordance with the manufacturer's requirements.





**public works**

Department:  
Public Works  
REPUBLIC OF SOUTH AFRICA

# DEPARTMENT OF PUBLIC WORKS

## STANDARD LEASE AGREEMENT FOR OFFICE AND FUNCTIONAL ACCOMMODATION

BUILDING NAME AND ADDRESS:

CLIENT NAME: SOUTH AFRICAN POLICE SERVICES

PROPERTY CODE:

FILE NO:



public works

Department:  
Public Works  
REPUBLIC OF SOUTH AFRICA

## STANDARD LEASE AGREEMENT FOR OFFICE AND FUNCTIONAL ACCOMMODATION

## INDEX

CLAUSE	HEADING	PAGE
1	PARTIES	4
2	DEFINITIONS AND INTERPRETATION	4
3	THE LEASE	7
4	DURATION AND RENEWAL	7
5	THE RENTAL	8
6	USE OF THE PREMISES	9
7	OCCUPATION OF THE PREMISES	9
8	CONDITION OF THE PREMISES AT THE COMMENCEMENT DATE AND AT THE TERMINATION DATE	9
9	FIXTURES	11
10	EXPENSES, MAINTENANCE AND REPAIRS	11
11	OBLIGATIONS OF THE LESSOR	12
12	OBLIGATIONS OF THE LESSEE	14
13	INSURANCE	15
14	FIRE FIGHTING EQUIPMENT AND LIFTS	16
15	ALTERATIONS, ADDITIONS AND IMPROVEMENTS	16
16	DAMAGE TO OR DESTRUCTION OF THE PREMISES	17
17	BREACH	18
18	MANAGEMENT RULES	19
19	LESSORS RIGHT OF ENTRY AND CARRYING OUT OF WORKS	19
20	CESSION, ASSIGNMENT AND SUB-LETTING	19
21	NON-WAIVER	20
22	RIGHT OF FIRST REFUSAL	20
23	SALE OF PREMISES	21
24	WHOLE AGREEMENT	21
25	DOMICILIUM CITANDI ET EXECUTANDI	21
26	WARRANTY OF AUTHORITY	22
27	SEVERABILITY	22
28	SUSPENSIVE CONDITION	23
29	DISPUTE RESOLUTION	23
30	ARBITRATION	24

## 1 PARTIES

The parties to this agreement are:

the party identified in item 1.1 of Schedule A (hereinafter referred to as the “lessor”);

and

the Government of the Republic of South Africa, herein represented by the Director-General of the Department of Public Works or his/ her duly authorised delegate, (hereinafter referred to as the “lessee”).

## 2 DEFINITIONS AND INTERPRETATION

2.1 In this agreement, unless the context indicates otherwise, the following words have the meaning assigned to them hereunder:

**"adjustment date"** – means the date referred to in item 8 on Schedule A on which date the escalated rate comes into effect;

**"the/this agreement"** – means the agreement set out in this document together with Schedule A, Schedule B, Schedule C, Schedule D thereto and any other schedules annexed thereto;

**"building"** – means the entire structure known by the name as set out in item 2.2 of Schedule A and situated on the property set out in item 2.4 of Schedule A;

**"calendar day"** – means the period from midnight to midnight, inclusive of weekends and public holidays;

**"commencement date"** – means the date on which this lease commences, which date may not be earlier than the date of occupation OR a month after the lessor has completed the agreed Tenant installations. Such date will be stipulated in item 7 on Schedule A;

**"commencement rental"** – means the rental payable at the commencement of the lease as is stipulated in Schedule B;

**"day"** – means any day other than a Saturday, Sunday or official public holiday in the Republic of South Africa;

**"escalation rate"** – means the percentage mentioned in item 9 on Schedule A, which adjusts the rental on every adjustment date;

**"initial lease period"** – means the initial period of the lease, as set out in item 3 of Schedule A;

**"lessee"** – means the Government of the Republic of South Africa, (herein represented by the Director-General of the Department of Public Works or his duly authorised delegate) its successor-in-title and/or its duly authorised employees, agents, intermediaries, representatives and if and to the extent applicable, shall extend to the invitees;

**"lessor"** – means the party identified in item 1.1 of Schedule A (herein represented by the person identified in item 1.1.4 of Schedule A who by his/her signature hereto warrants that she/he is authorised to sign this agreement on behalf of the lessor), its successor-in-title and/or its duly authorised employees, agents, intermediaries and/or representatives;

**"occupant"** – the body defined in item 1.2 of Schedule A, being the body which will physically occupy the premises for the duration of the agreement of the lease;

**"party / parties"** – means the lessee, and the lessor or any of them as determined by the context;

**"premises"** – means the building and/or the structure and/or the land, or portions thereof, as set out in item 2.1 of Schedule A and a plan of which is attached as Schedule D, which forms the subject of this agreement;

**"secondary lease period"** – means the period mentioned in item 4 of Schedule A, for which this agreement may be extended by the lessor or the lessee from the date on which the initial lease period expires;



**"signature date"** – means the date of signature of this agreement by the party which signs last in time;

**"termination date"** – means the date stipulated in item 10 of Schedule A on which the lease terminate, unless extended for the secondary lease period, as more fully detailed in clause 4 hereof;

**"VAT"** – means Value-Added Tax in terms of the VAT Act; and

**"VAT Act"** – means the Value-Added Tax Act (No. 89 of 1991), together with all amendments thereto and all regulations published thereunder from time to time;

- 2.2 The clause headings of this agreement have been inserted for reference purposes only and shall not be taken into account in its interpretation. Unless the context indicates otherwise, words importing the singular shall include the plural, words importing persons shall include natural persons and legal persons and the state and *vice versa*;
- 2.3 If a provision in a definition is a substantive provision conferring rights or imposing obligations on any party, effect shall be given to it as if it were a substantive provision in the body of the agreement, notwithstanding that it is in the definitions clause.
- 2.4 Any reference to an enactment, regulation, rule or by-law is to that enactment, regulation, rule or by-law as at the signature date, and as amended or replaced from time to time.
- 2.5 Where any number of days is prescribed, such number shall exclude the first and include the last day, unless the last day falls on a Saturday, Sunday or public holiday in the Republic of South Africa, in which case the last day shall be the next succeeding day which is not a Saturday, Sunday or public holiday.
- 2.6 The use of the word "including" followed by a specific example/s shall not be construed as limiting the meaning of the general wording succeeding it and the *eiusdem generis* rule shall not be applied in the interpretation of such general wording or such specific example/s.



- 2.7 The expiration or termination of this agreement shall not affect those provisions of this agreement which expressly provide that they will operate after any such expiration or termination or which of necessity must continue to have effect after such expiration or termination, notwithstanding the fact that the clauses themselves do not expressly provide this.
- 2.8 In its interpretation, the *contra proferentem* rule of construction shall not apply (this agreement being the product of negotiations between the parties) nor shall this agreement be construed in favour of or against any party by reason of the extent to which any party or its professional advisors participated in the preparation of this agreement.

### 3 THE LEASE

The lessor hereby leases the premises to the lessee who hires the premises on the terms and conditions set out in this agreement, for occupation by the occupant, it being specifically recorded and notwithstanding anything to the contrary contained in this agreement, that the only persons who are mandated to negotiate, enter into, amend or otherwise agree the terms and conditions of this agreement are lessor and lessee provided that any terms and conditions which are specifically exercisable by the occupant in terms of this agreement, shall be so exercisable despite this clause 3.;

### 4 DURATION AND RENEWAL

- 4.1 This agreement shall commence on the commencement date and shall endure for the period as specified in item 3 of Schedule A as the initial lease period.
- 4.2 Upon the expiry of the initial lease period, the lessee shall have the option of renewing this agreement. The parties will agree on a market related rental for the premises however the annual escalation rate applicable during the secondary lease period shall be limited to headline inflation or the escalation rate applicable during the initial lease period, whichever is the greater;
- 4.3 All extensions to the lease period in this agreement, and any changes to the terms and conditions of lease during such extended period, shall be concluded in writing and signed

by the parties prior to the termination date or expiry of any extended period, as the case may be.

## **5 THE RENTAL**

- 5.1 During the initial lease period, with effect from the commencement date, the monthly rental payable by the lessee to the lessor shall be as specified in Schedule B.
- 5.2 The lease commences with the commencement rental where after the rental shall escalate each year, on each adjustment date, in accordance with the compounded escalation rate as set out in item 9 on Schedule A.
- 5.3 The lessor warrants that the space and parking leased is/are as indicated in the Schedule B. Should it be discovered that the space or parking provided is/are lesser, any amount paid for the non-existent space and/or parking will be recovered as per clause 10.
- 5.4 For leases longer than five (5) years, the rate or tariff agreed between the parties shall be subject to review after the expiry of the fifth year (i.e. de-escalation). The object of the review will be to bring the rates in line with the market, should the parties not agree on the review rate or tariff (as provided in Schedule B), the matter will be resolved as per the Dispute resolution clause beneath.
- 5.5 The rental shall be paid by the lessee to the lessor, monthly in advance on or before the 7th (seventh) day of each and every month.
- 5.6 All payments made by the lessee to the lessor in terms of this agreement, shall be effected by electronic payment directly into the lessor's nominated bank account.
- 5.7 The parties agree that all rentals payable in terms of this agreement shall include VAT where such tax is payable. The lessor shall specify such tax for record and tax purposes separately from the basic rental.
- 5.8 The lessee undertakes to pay all VAT, at the standard rate applicable from time to time, leviable on any amounts payable by the lessee in terms of this agreement.
- 5.9 The lessor shall be liable to pay all rates, taxes, other regulatory amounts and levies in respect of the premises to the relevant authority as well as any expenses and increases.

## **6 USE OF THE PREMISES**

- 6.1 The lessee records that she/he will use the premises for the purpose specified in item 5 of Schedule A and for any legitimate Government purpose. Where the lessee uses the premises for a purpose other than its intended purpose, the onus shall rest on the lessee to obtain and maintain all necessary permits and/or consents for the use of the premises for that purpose.
- 6.2 The lessor hereby warrants and undertakes that the premises are fit for use for the purpose set out in item 5 of Schedule A.
- 6.3 The lessor shall be obliged to obtain such consents and authorisations (excluding trade and other licences) as may be required by competent authorities or title conditions to enable the lessee to use the premises for the purpose referred to in 6.1.

## **7 OCCUPATION OF THE PREMISES**

The lessor warrants the lessee's right to free and undisturbed possession of the premises from the commencement date until termination of this agreement, subject thereto that any delay in taking possession due to avoidable actions or omissions of the lessee, shall not be regarded as a delay on the part of the lessor. The date of occupation shall be the date on which the lessee occupies the premises, which shall also be the date of commencement of the lease

## **8 CONDITION OF THE PREMISES AT THE COMMENCEMENT DATE AND AT THE TERMINATION DATE**

- 8.1 Schedule C contains details of the installations required by the lessee, the party responsible for effecting those installations and the party who bears the costs in respect thereof. Schedule C also contains the obligations, if any, of the lessee in regard to the removal thereof on termination of this agreement. To the extent that any party does not make the installations listed opposite its name in Schedule C, either of the other parties may have such installations made at the reasonable cost thereof and the party which was responsible for such installation shall become liable for such reasonable amount;
- 8.2 In compliance with the National Building Regulations and Building Standards Act (Act 103 of 1977) as amended, and the Occupational Health and Safety Act (Act 85 of 1993) as

amended, and /or any other applicable legislation, the Landlord shall provide the Lessee with the following Certificates of Compliance, where applicable, in respect of the following equipment, prior to occupation of the premises. The lessee shall in writing accept that the lessor has complied with terms of the agreement and that the building is ready and available and ready for use.

Lifts

Electrical Certificate

Firefighting equipment

Gas Installation

Glass certificate

Air-Conditioning Units

- 8.3 The lessee shall, within 30 days of occupation of the premises, furnish the lessor with three (3) dates and times, which dates must be within twenty-one (21) days of occupation, to convene a meeting to inspect the premises. The lessor shall accept a date, from those furnished, that is suitable to him. At such meeting the parties, including the occupant, shall jointly inspect the premises, so as to ascertain any damage or defect in the premises and the general condition of the premises and to record them in a list which all three parties shall sign.
- 8.4 The lessor shall within thirty (30) days of such inspection (or such longer period as may be reasonably necessary to repair the defects) repair the defect(s).
- 8.5 The lessor shall furnish dates and times at least fourteen working (14) days prior to the termination of the agreement for the inspection of the premises after termination of the agreement. Within 14 days after the expiry of this agreement, the lessor shall ensure that the following lists are compiled and delivered to the lessee:
- 8.5.1 A list of all the items where the parties agree that such items are damaged or defective and that the lessee is liable; and
- 8.5.2 A list of the items, which are damaged or defective and which in the opinion of the lessor the lessee is liable for, whereas the lessee denies liability.

8.6 The items recorded in the list contemplated in clause 0 shall be replaced as per agreement between the parties. Should the parties fail to reach such an agreement within seven (7) days from the date of delivery of the lists to the lessee, the dispute may by agreement between the parties be referred to an independent professional who shall act as a mediator in an attempt to resolve the dispute.

## 9 FIXTURES

The parties agree that for the purposes of the interpretation of this clause and of this agreement, fixtures shall refer to movable or immovable fittings installed by the lessee and required for its purposes, such as computer cables and telephone systems. The lessee shall be entitled, at its expense and with the written consent of the lessor, which consent shall not be unreasonably withheld (alternatively, as arranged in Schedule C), to install fixtures (which shall remain the property of the lessee) on the premises; provided that, after the termination of this agreement:

- 9.1 fixtures may be removed by the lessee on condition that the premises are restored to the condition in which they were before the installation of the fixtures, fair wear and tear excepted; or
- 9.2 Should the lessee fail or neglect to remove the fixtures and restore the premises in a substantially similar condition it was on commencement, fair wear and tear excepted, the lessor can remove the fixtures and recover the reasonable costs thereof from the lessee.

## 10 EXPENSES, MAINTENANCE AND REPAIRS

- 10.1 Subject to 10.3 below, the lessor shall be responsible for and pay all and any expenses in respect of the premises.
- 10.2 The lessor shall be responsible for contracting with the suppliers of utilities to the premises referred to in this clause 10.1 above and shall be directly responsible for payment of these charges and any connection fees and deposits in respect thereof.
- 10.3 The lessee shall be responsible for and will pay the cost of all electricity, water and/or sewerage consumed on the premises for the duration of this agreement. Electricity and/or



water and/or sewerage consumed shall be charged according to the relevant meter reading, provided that the consumption of water, electricity and sewerage in the premises shall be proved *prima facie* by reading of meters or sub-meters and recording same. The lessor shall be responsible for contracting with the suppliers of utilities to the premises referred to in this clause and shall be directly responsible for payment of these charges and any connection fees and deposits in respect thereof.

10.4 In the event of the premises being a portion of a building and it consequently being necessary to determine the lessee's *pro rata* share in respect of maintenance or consumption of necessary services, the *pro rata* share of the lessee, for the purpose of this agreement, shall be determined by calculating the area of the premises as a fraction of the total area of the building.

10.5 Should the lessor fail to pay expenses or to undertake repairs for which the lessor is liable in terms of this agreement, the lessee may remind the lessor in writing, and should the lessor still be in default 30 days after receipt of such reminder (or such longer period which the parties may have agreed upon) the lessee shall be entitled to demand specific performance or to pay such expenses or to undertake such repairs (if and to the extent agreed between the parties) and to recover the amounts thus disbursed from the rental due to the lessor by set off (if and to the extent agreed between the parties) or by legal action. Where the lessee has to attend to the repairs, the lessee will be entitled, but not obliged, to use the Landlord' contractors. A certificate by the lessee of such expenses shall be *prima facie* proof thereof.

10.6 The lessee will also be entitled to recover any undisputed amount overpaid to the lessor in terms of this agreement as per the provision of 10.5.

## 11 OBLIGATIONS OF THE LESSOR

In addition to any other obligations contained in this agreement, the lessor shall be responsible for:

11.1 The payment of assessment rates, taxes and fixed municipal levies;

11.2 Insuring the building as provided for in clause 13 below;

- 11.3 Installation and maintenance of mechanical and fire services equipment, including fire detection equipment, fair wear and tear excepted, as further stipulated in clause 14 hereof;
- 11.4 Landscape maintenance of the premises, if applicable;
- 11.5 Providing, at the lessor's expense, all electric, fluorescent, and incandescent light bulbs required in the premises;
- 11.6 Maintenance of, and for all repairs and replacements becoming necessary from time to time in or to, the roofs and outside walls of the buildings including the maintenance and repair of the structure of the buildings, and all systems, works and installations contained therein;
- 11.7 Maintaining in good order and condition the exterior, roof, gutters and down-pipes of the premises and shall make good any structural defects, other than damage caused by the lessee;
- 11.8 Normal maintenance and repairs (including painting) of both the exterior and interior of the premises, including the cleaning of the exterior of the premises as well as windows, in a high rise building;
- 11.9 Operation (including maintenance and repairs) of the air-conditioning system and the lifts during normal office hours or during such times as may be agreed upon;
- 11.10 Water and electricity consumption to the extent that these are not separately metered for the lessee;
- 11.11 Municipal rates (existing and future) levied on ownership (including rates increases);
- 11.12 Installation and maintenance of the fire extinguishing and fire detection equipment as stipulated in clause 14; and
- 11.13 Replacement of floor covering (carpeting etc.) at the expiry of their agreed lifetime which in the case of carpeting is 5 years from the date of installation;
- 11.14 Submission of valid annual tax certificate/sustain CSD compliance throughout the lease;

- 11.15 Compliance with Occupational Health and Safety and Act (Act No. 85 of 1993);
- 11.16 Compliance with Department of Labour's applicable standards annually – Certification of Occupation;
- 11.17 Quarterly fumigation of the premises. Without prejudice to any rights and/or remedies available to the lessor in terms of this agreement, where any losses, expenses, costs, damages or breakages are attributable to any act or omission of the lessee and/or negligence or wilful intent of the lessee, the lessor shall be entitled to attend to the necessary and recover the reasonable cost thereof from the lessee.
- 11.18 Should the Lessee/occupant be deprived of the full use and enjoyment of the premises through acts or omissions of the lessor e.g. non-functioning air conditioning system, lifts, water shortage etc, the lessee will be entitled to a pro rata reduction in the rental amount.

## **12 OBLIGATIONS OF THE LESSEE**

In addition to any other obligations contained in this agreement, the lessee shall:

- 12.1 Not use the premises or allow them to be used, in whole or part, for any purpose other than that of the business;
- 12.2 Take good and proper care of the interior of the buildings;
- 12.3 Be responsible for all reasonable security, manned or otherwise, necessary to protect the premises;
- 12.4 Not cause or commit any unreasonable nuisance on the premises or cause any annoyance or discomfort to neighbours or the public;
- 12.5 Not unreasonably leave refuse or allow it to accumulate in or about the premises;
- 12.6 Refrain from interfering with the electrical, plumbing, or gas installations or systems serving the premises;
- 12.7 Take all reasonable measures to prevent blockages and obstructions from occurring in drains, sewerage pipes and water pipes serving the premises;



- 12.8 At all times comply with any law, by-law or regulation of the local authority relating to the conduct of its business at the premises and also with the conditions of the title deed under which the premises are held by the lessor;
- 12.9 Not be permitted to place such electrical or other signage on the exterior of the premises without the prior written consent of the lessor;
- 12.10 Forthwith disclose in writing to the lessor details of any act, matter or thing, stored or carried out upon the premises which may affect, vitiate or endanger the fire insurance policy in respect of the property or which may result in an increase of the fire insurance premium;
- 12.11 Undertake domestic cleaning of the interior of the premises, including domestic services such as the provision of toilet paper, soap, towels, etc.; excluding common areas;
- 12.12 Be responsible for the costs of water, electricity and sewerage consumption to the extent that these are separately metered as fully set out in clause 10 above; and
- 12.13 Be responsible for the costs of refuse removal and sanitary services.

### **13 INSURANCE**

- 13.1 The lessor shall comprehensively insure the property and the building, and the lessor's fittings at its replacement value, at the lessor's own risk and cost.
- 13.2 The lessee and the occupant may not after the commencement of the lease do, or allow anything that is contrary to the provisions of the insurance policy, which will cause an increase in the premiums of any insurance policy held by the lessor over the property, provided that the conditions of the insurance policy will be communicated in writing to the lessee from time to time.
- 13.3 Should the lessee knowingly do or cause to be done anything that causes an increase in the premiums of such insurance policy, the lessee will be liable for the increase in the premiums occasioned by the actions of the lessee. The lessor shall furnish to the lessee proof from the insurer of such increase before any payment shall be due from the lessee.

13.4 The lessor shall not be liable for any damage which the lessee may suffer as a consequence of rain, wind, hail, lightning, fire, earthquake, storm, riots, strikes, actions by enemies of the State or in consequence of the interruption of any facility or service supplies to the premises by third parties, unless such damage could have reasonably been prevented by the lessor.

13.5 The lessor shall not be liable for any accident, injury or damage incurred by the lessee, his employees, agents or visitors, in or near the premises, unless this could have reasonably been prevented on the part of the lessor.

#### **14 FIRE FIGHTING EQUIPMENT AND LIFTS**

14.1 The lessor shall be obliged to install, maintain and operate on the premises fire extinguishing and fire detection equipment complying with the National Building Regulations and Building Standards Act (Act No. 103 of 1977) as amended, and/or any other applicable legislation.

14.2 The lessor shall be obliged to maintain the lifts and ensure that regular checks are done in accordance with the Occupational Health and Safety Act (Act No. 85 of 1993) as amended and /or any other applicable legislation.

14.3 The lessor shall provide the lessee with quarterly reports of regular checks done on the fire extinguishers and lifts to ensure safety and security of the occupants of the premises.

#### **15 ALTERATIONS, ADDITIONS AND IMPROVEMENTS**

15.1 The lessee shall not make any alterations or additions to any of the buildings, the premises or any part thereof, without the lessor's prior written consent, but the lessor shall not withhold its consent unreasonably to any such alteration or addition. In the event that the lessee does make any such prohibited alterations or additions, it is agreed between the parties that such alterations and/or additions shall be come an immovable part of the respective building or premises to which it is made and shall thus be owned by the lessor who shall not be obliged to compensate the lessee in respect of such alterations and/or additions. Where the lessee has given its prior written consent to any alteration or addition and such alteration or addition has become an immovable part of the building or premises

and has added value to the building or premises, the lessor shall not be obliged to compensate the lessee in respect thereof unless otherwise agreed between the parties prior to such alteration or addition being made.

15.2 Notwithstanding the aforesaid, the lessee shall be entitled to make any non- structural alterations or additions to the interior of the premises without the lessor's prior written consent, provided that the lessee may, on the expiration of this agreement, remove such non-structural alterations or additions as it may have made, provided that simultaneously with any such removal, it reinstates the premises or part of the premises in question, at the lessee's cost, to their same condition (fair, wear and tear excepted) as they were in prior to the carrying out of such alterations or additions.

## **16 DAMAGE TO OR DESTRUCTION OF THE PREMISES**

16.1 In the event of the premises being destroyed and therefore rendered totally unfit for occupation, this agreement shall be terminated automatically unless the destruction of the premises is due to the wilful intent or negligence of the lessee and/or occupant.

16.2 In the event of the premises being damaged and remaining partially suitable for the purposes of the lessee, the parties shall be entitled to terminate this agreement by thirty (30) days' notice in writing given to the other party within thirty (30) days after such destruction or damage.

16.3 Should no notice in terms of 16.2 above be given, then this agreement shall continue and the lessor shall be obliged to proceed expeditiously with the work of rebuilding the premises. Should the parties continue with the agreement, the lessee shall be entitled to a reduction in rental to the extent to which the lessee is deprived of the full and beneficial use and occupation of the premises until such time as the premises have been rebuilt or re-instated.

16.4 Should there be any dispute as to the extent to which the premises have been damaged and/or the extent to which the premises are unfit for occupation and capable of being used for the purpose for which they are let, the dispute shall be referred to an expert, who shall act as an expert and not as an arbitrator, and whose decision shall be final and

binding on the parties. The parties shall jointly agree on who the expert shall be, failing which the expert shall be appointed by the chairperson of the Law Society of South Africa or his delegate.

## 17 BREACH

17.1 Subject to any specific provision in this agreement to the contrary, should;

17.1.1. the rental or any other amount payable by the lessee in terms of this agreement not be paid by due date or should the lessee commit or suffer or permit the commission of any breach of any of the remaining conditions of this agreement and fail to pay such rental or amount or to remedy such breach within 30 (thirty) days after receipt of written notice by the lessor requiring it to do so, or such longer period as may be reasonable in the circumstances,

17.1.2. subject to due process of law, the lessor shall be entitled to claim specific performance, cancel this agreement and retake possession of the premises (without prejudice to any of its other rights under this agreement or at all) and /or claim damages.

17.1.3. should the lessor and subsequent to an alleged breach by lessee or expiry of the lease, disturb the peaceful possession of the premises by the lessee without following due process of law and thereby disrupt government services, the lessor will be liable to compensate the lessee and occupant. The parties hereby agree that the compensation payable for each day of disruption will be the equivalent of a total monthly rental last payable in terms of this lease i.e. 2 days of disturbance/disruption the compensation is the equivalent of 2 monthly rentals. This clause does not limit or preclude the lessee or occupant's common law delictual rights and remedy should the actual loss suffered be more than the compensation provided for in this clause,

17.1.4 in addition to the ordinary factors which affect the validity of a contract, the parties agree that any unlawful act committed by the lessor which was material in the

conclusion the contract will impair the validity of this contract warranting the lessee to terminate this agreement.

17.2 Should either party breach any obligations in terms of this agreement and fail to remedy such breach within 30 (thirty) days of written demand from the aggrieved party to do so, or such longer period as may be reasonable in the circumstances, the aggrieved party shall be entitled to cancel this agreement or claim specific performance, in either case, without prejudice to the aggrieved party's rights to claim damages from the offending party.

## **18 MANAGEMENT RULES**

The lessee shall comply with all management rules as may be prescribed by the lessor from time to time provided that they are fair, reasonable and justifiable.

## **19 LESSORS RIGHT OF ENTRY AND CARRYING OUT OF WORKS**

The lessor's representatives, agents, servants and contractors may at reasonable times and on reasonable notice (save for the in the event of an emergency), without thereby giving rise to any claim or right of action on the part of the lessee or the occupant of the property or any part thereof, enter the property or any of the buildings in order to inspect them, to carry out any necessary repairs, replacements, or other works, or to perform any other lawful function in the *bona fide* interests of the lessor or the lessee or the occupant, but the lessor shall ensure that this right is exercised with due regard for and a minimum of interference with the beneficial enjoyment of the property by those in occupation thereof, and provided further that such rights will be exercised subject to the lessee's specific security requirements relating to the physical security of the property.

## **20 CESSION, ASSIGNMENT AND SUB-LETTING**

The lessee shall not, except with the prior written consent of the lessor, which shall not be unreasonably withheld:

- 20.1 cede or assign all or any of the rights and obligations of the lessee under this agreement; or
- 20.2 sublet the premises in whole or in part; or



20.3 give up possession of the premises or any portion thereof to any third party.

## 21 NON-WAIVER

21.1 Neither party shall be regarded as having waived, or been precluded in any way from exercising, any right under or arising from this agreement by reason of such party having at any time granted any extension of time for or having shown any indulgence to the other party with reference to any payment or performance hereunder, or having failed to enforce, or delayed in the enforcement of any right of action against the other party.

21.2 The failure of either party to comply with any non-material provision of this agreement shall not excuse the other parties from performing their obligations hereunder fully and timeously.

## 22 RIGHT OF FIRST REFUSAL

22.1 The Lessor hereby grants to the Lessee and the Lessee hereby accepts the right of first refusal to purchase the property.

22.2 Pursuant to the right granted by the Lessor in favour of the Lessee in 22.1, the Lessor shall not dispose of any part or whole of the property at any time except in accordance with the following circumstances;

22.2.1 if the Lessor intends to so dispose, the Lessor shall deliver to the Lessee a written notice offering ("the offer notice) so to dispose, to the Lessee at a consideration (which shall sound in money in South African currency) and on such terms as may be stipulated in the offer notice; and

22.2.2 the Lessee may, at any time within 60 days after the receipt of the offer notice, accept it by giving written notice to the Lessor to that effect.

22.3 If the Lessee does not accept the offer within the aforesaid period, the Lessor may dispose of the property on terms no more favourable than the terms contained in the offer notice within a period of 90 (ninety) days after the Lessee has rejected the offer, whereafter the Lessor shall again be obliged to follow the procedure in clause.

22.4 Should the Lessee not exercise its right of first refusal in relation to the property or in relation to any rights thereto or pursuant thereto, the relevant acquirer shall acquire the property free of the right of first refusal contained in this clause.

## 23 SALE OF PREMISES

23.1 Transfer of the ownership of premises from the Lessor to a third party pursuant to a sale thereof shall not in any way affect the validity of this agreement. It shall accordingly, upon registration of transfer of the premises into the name of the purchaser, remain of full force and effect save that the purchaser shall be substituted as Lessor and acquire all rights and be liable to fulfil all the obligations which the Lessor, as the Lessor, enjoyed against or was liable to fulfil in favour of the Lessee in terms of the this agreement.

23.2 Nothing shall prevent the Lessor from advertising the premises as “for sale” or as “to let” as long as it does not disturb the Lessee in its use and enjoyment of the premises and any activities which the Lessor undertakes are undertaken on reasonable notice to the occupant.

## 24 WHOLE AGREEMENT

24.1 This is the entire agreement between the parties inclusive of all bid/tender documents.

24.2 Neither party relies, in entering into this agreement, on any warranties, representations, disclosures or expressions of opinion, which have not been incorporated into this agreement as warranties or undertakings.

24.3 No variation, alteration, or consensual cancellation of this agreement shall be of any force or effect unless reduced to writing and signed by the duly authorised representatives of both parties.

## 25 DOMICILIUM CITANDI ET EXECUTANDI

25.1 The parties respectively choose as *domicilium citandi et executandi* and as the address for the serving of notices the address appearing underneath their names in Schedule A (and the lessor is explicitly barred from serving such notices on officials and offices in the Regions/Provinces).

25.2 Any notice given by one of the parties to the other (“the addressee”) which:

26.2.1 is delivered by hand to a responsible person during ordinary business hours at the physical address chosen as the addressee’s *domicilium citandi et executandi* shall be deemed to have been received by the addressee on the date of the delivery, unless the contrary is proved;

26.2.2 is posted by prepaid registered post from an address within the Republic of South Africa to the addressee at the addressee’s *domicilium citandi et executandi*, shall be deemed to have been received by the addressee on the tenth (10<sup>th</sup>) business day of the date of posting unless the contrary is proved; or

26.2.3 is emailed to the chosen email address, during ordinary business hours shall be presumed to have been received by the addressee at the time of transmission of the email, alternatively, if not emailed during normal business hours then at twelve o’ clock on the 1<sup>st</sup> business day following the day on which it was emailed.

25.3 Either party shall be entitled, on 14 days’ notice to the other, to change the address of his *domicilium citandi et executandi*.

## 26 WARRANTY OF AUTHORITY

The parties hereby warrant that each of them has the power, authority and legal right to sign and perform this agreement and that this agreement has been duly authorised by all necessary actions of its directors, to the extent applicable, and constitutes a valid and binding obligation on it in accordance with the terms thereof.

## 27 SEVERABILITY

Any provision in this agreement which is or may become illegal, invalid or unenforceable in any jurisdiction affected by this agreement shall, as to such jurisdiction, be ineffective to the extent of such prohibition or unenforceability and shall be treated *pro non scripto* and severed from the balance of this agreement, without invalidating the remaining provisions of this agreement or affecting the validity or enforceability of such provision in any other jurisdiction.



## 28. SUSPENSIVE CONDITION

Where the standard Tenant Installation allowance by the Lessor is not sufficient to cover all the required Tenant Installation, this lease contract is subject to the availability of the necessary additional funds/budget on the part of the lessee.

## 29. DISPUTE RESOLUTION

In the event of a dispute, disagreement or claim arise between the parties (called hereafter "the dispute") connected with or concerning this Agreement, the parties shall first endeavour to resolve the dispute by negotiation in good faith. This entails that the one party invites the other in writing to a meeting in an attempt to resolve the dispute within 7 (seven) days from date of the written invitation.

If the dispute has not been resolved by such negotiation, the parties shall submit the dispute to mediation to be administered by a property specialist or lawyer nominated by the parties by agreement or alternatively by the relevant professional body of property specialist or Law Society or Bar Council.

Should the parties fail to resolve the dispute through negotiation and/or mediation, the dispute shall be referred to arbitration, only if the parties agree thereto, in which event the arbitration clause hereunder shall apply.

## 30. ARBITRATION

If either Party to this Agreement is unwilling to accept mediation or is unwilling to accept the opinion expressed by the mediator, then either Party may require that the dispute be referred to arbitration.

The dispute will be referred to Arbitration by written notice delivered to the other, within 20 days of the declaration of the dispute if there is no mediation or within 20 days of the issue of the mediator's opinion if mediation takes place.

Such arbitrator shall be selected by agreement between the Parties, or if no agreement is reached after 10 days from deliberation on the identity of the Arbitrator; it is agreed that

the arbitrator will be nominated on request of either of the party by the president of the Arbitration Foundation of South Africa, or its successor-in-title.

The arbitrator shall have power to open up, review and revise any certificate, opinion, decision, requisition or notice relating to all matters in dispute submitted to him and to determine all such matters in the same manner as if no such certificate, opinion, decision, requisition or notice had been issued. The arbitrator shall be entitled to make award, including an award for specific performance, an interdict, damages or otherwise as he in his discretion may deem fit and appropriate.

If a request is made by the arbitrator for a document or any item to be submitted, such document or item must be submitted within ten (10) days of the request.

The arbitration shall be conducted in the English language at \_\_\_\_\_ or such other place as the Parties may agree on in writing.

The costs of and incidental to the award shall be in the discretion of the arbitrator, who may determine the amount of the costs, and shall direct by whom and to whom and in what manner they shall be borne and paid.

The award of the arbitrator shall be final and binding on the Parties though subject to review on any of the usual grounds for review. Any Party shall be entitled to apply to the Courts to have such award made an order of court if the party concerned fails to heed to the terms of the award. Nothing in this clause shall prevent either Party seeking urgent relief in the High Court of South Africa and for this purpose, the Parties consent to the exclusive jurisdiction of the High Court of South Africa.

SIGNED AT..... ON THIS THE .....DAY OF..... 20....

**WITNESSES**

1. ....  
 FULL NAME AND SIGNATURE

2. ....  
 FULL NAME AND SIGNATURE

.....  
**SIGNATURE OF LESSOR / REPRESENTATIVE**

.....  
 FULL NAMES  
 Duly authorised as per attached resolution.

SIGNED AT..... ON THIS THE .....DAY OF..... 20....

**WITNESSES**

1. ....  
 FULL NAME AND SIGNATURE

2. ....  
 FULL NAME AND SIGNATURE

.....  
**SIGNATURE OF LESSEE / REPRESENTATIVE**

.....  
 FULL NAMES

.....  
 CAPACITY  
 Duly authorised as per Departmental delegation dated .....



SIGNED AT..... ON THIS THE .....DAY OF..... 20....

.....

**SIGNATURE OF OCCUPANT**

.....

**FULL NAME**

.....

**CAPACITY**

Duly authorised as per Departmental delegation dated .....